



# FUEL SYSTEM & CARBURETION

## Section 3B – Fuel Pump, Recirculation System, Reed Valve Assembly and Auto Enrichner

### Table of Contents

Fuel Pumps .....	3B-1	System Description .....	3B-7
General Information .....	3B-1	Testing Fuel Recirculation System .....	3B-7
Fuel Pump Description/Operation .....	3B-1	Reed Valve Assembly .....	3B-8
Checking for Restricted Fuel Flow Caused by Anti-Siphon Valves .....	3B-2	Removing and Inspecting Reed Valve Assembly .....	3B-8
Testing .....	3B-2	Inspecting and Installing Reed Block Assembly .....	3B-9
Troubleshooting Fuel Pump .....	3B-2	Reed Plate, Adaptor Plate and Auto Enrichner .....	3B-10
Special Tools .....	3B-3	Auto Enrichner .....	3B-11
Removing/Disassembling Fuel Pump .....	3B-3	System Description .....	3B-11
Assembling and Installing Fuel Pump .....	3B-4	Testing Auto Enrichner .....	3B-12
Fuel Pump Exploded View .....	3B-6		
Fuel Recirculation System .....	3B-7		

**3  
B****⚠ DANGER**

**FIRE AND EXPLOSION HAZARD. Observe fire prevention rules, particularly NO SMOKING. Before servicing any part of the fuel system, disconnect electrical system at the battery. Drain the fuel system completely. Use an approved container to collect and store fuel. Wipe up any spillage immediately. Materials used to contain spillage must be disposed of in an approved receptacle. Any fuel system service must be performed in a well ventilated area.**

**FUEL LEAKAGE FROM ANY PART OF THE FUEL SYSTEM CAN BE A FIRE AND EXPLOSION HAZARD WHICH CAN CAUSE SERIOUS BODILY INJURY OR DEATH. Careful periodic inspection of the entire fuel system is mandatory, particularly after engine storage. All fuel components, including fuel tanks, whether plastic, metal, or fiberglass, fuel lines, primer bulbs, fittings, swelling, and must be inspected for corrosion. Any sign of leakage or deterioration necessitates replacement before further engine operation.**

## Fuel Pumps

### General Information

#### Fuel Pump Description/Operation

The fuel pump is a crankcase-pressure-operated, diaphragm-type pump. Crankcase pulsating pressure is transferred by way of a passage (hole) from the crankcase to the fuel pump.

When the piston travels upward a vacuum is created in the crankcase. This vacuum pulls in the fuel pump diaphragm, the inlet check valve (in fuel pump) is opened fuel is drawn into fuel pump.

Downward motion of the piston forces out the fuel pump diaphragm, closes the inlet check valve (to keep fuel from returning to fuel tank) and opens the outlet check valve, forcing fuel to the carburetors.



## Checking for Restricted Fuel Flow Caused by Anti-Siphon Valves

While anti-siphon valves are helpful from a safety stand-point they clog, may be too small, or they may have too heavy a spring. The pressure drop that occurs with these valves can create operational problems and/or powerhead damage by restricting flow of fuel. Some symptoms of restricted (lean) fuel flow are:

- 1-Loss of fuel pump pressure
- 2-Loss of power
- 3-High speed surging
- 4-Preignition/detonation (piston dome erosion)
- 5-Engine hesitates upon acceleration
- 6-Engine runs rough
- 7-Engine quits and cannot be restarted
- 8-Engine will not start
- 9-Vapor lock

Any type of anti-siphon device must be located between the engine fuel inlet and fuel tank outlet. A method of checking [if such a device (or bad fuel) is a problem source] is to operate the engine with a separate fuel supply which is known to be good.

If it is found that the anti-siphon valve is the cause of the problem, either 1) replace the anti-siphon valve, or 2) replace it with a solenoid-operated fuel shutoff valve.

## Testing

Install clear fuel hose(s) between fuel pump and carburetor(s). Run engine, and inspect hose(s) for air bubbles. If air bubbles are found, see "Air Bubbles in Fuel Line". If air bubbles are NOT found, see "Lack of Fuel Pump Pressure".

## Troubleshooting Fuel Pump

<b>PROBLEM: Air Bubbles in Fuel Line</b>	
<b>Possible Cause</b>	<b>Corrective Action</b>
Low fuel in tank.	Fill tank.
Loose fuel line connection.	Inspect and tighten connections.
Fuel pump fitting loose.	Tighten fitting.
A hole or cut in fuel line.	Inspect condition of fuel lines and replace any found bad.
Fuel pump anchor screws loose.	Inspect and tighten all screws.
Fuel pump gaskets worn out.	Rebuild fuel pump.
<b>PROBLEM: Lack of Fuel Pump Pressure</b>	
<b>Possible Cause</b>	<b>Corrective Action</b>
Anti-siphon valve.	Refer to "Checking for Restricted Fuel Flow Caused by Anti-siphon Valves" preceding.
Air in fuel line.	"Air Bubbles in Fuel Line" preceding.
Dirty or clogged fuel filter.	Clean or replace filter.
Dirty or clogged fuel pickup in fuel tank.	Clean or replace pickup.
Worn out fuel pump diaphragm.	Rebuild pump.
Defective check valves in fuel pump.	Rebuild pump.
Pulse hole plugged.	Remove fuel pump and and clean out hole.
Diaphragm gasket distorted or out of place.	Align or replace gasket as necessary.



## Special Tools

Description	Part Number
Hose Clamp Pliers	FT-8900
RTV Sealant	92-90113--2

## Removing/Disassembling Fuel Pump

1. Loosen screw on sediment bowl.
2. Remove bowl from pump body.
3. Remove gasket and screen.

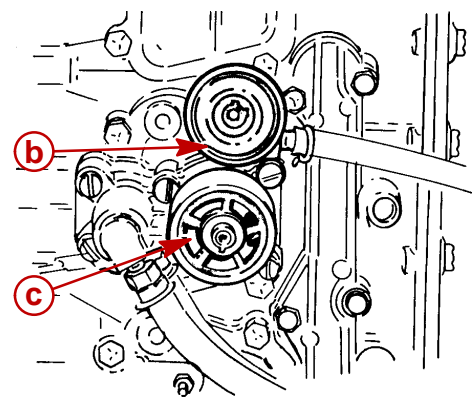
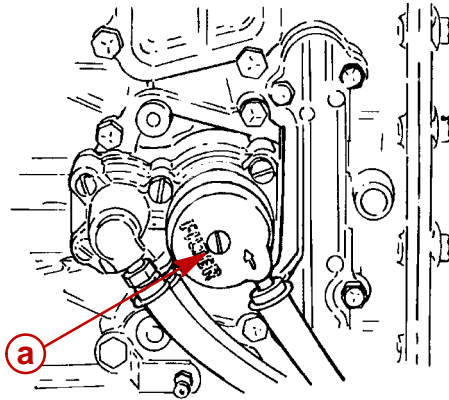

- a** - Screw
- b** - Gasket
- c** - Screen

4. Remove and disassemble fuel pump fitting, screws and washer, nuts, fuel pump body, booster spring retainer, booster spring, diaphragm, gasket, spacer, and spacer plate gasket.

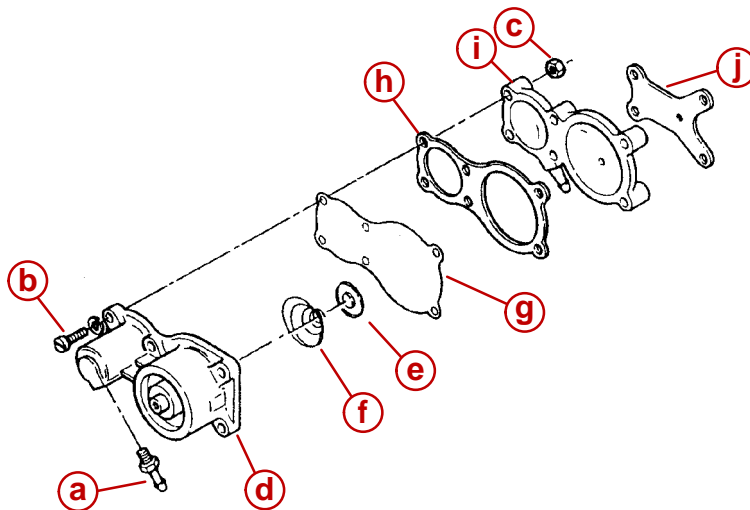

- a** - Fuel Pump Fitting
- b** - Screw and Washer
- c** - Nut
- d** - Fuel Pump Body
- e** - Booster Spring Retainer
- f** - Booster Spring
- g** - Diaphragm
- h** - Gasket
- i** - Spacer
- j** - Spacer Plate Gasket



5. Test fuel check valves by lightly pressing on plastic seats.
  - Be sure check valve seats when tension is released.
6. Replace fuel pump check valves as necessary.

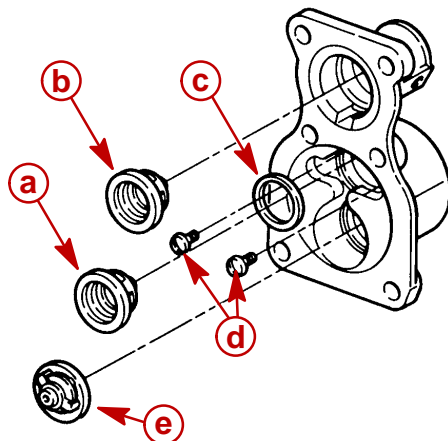

- a - Center Check Valve
- b - Second Stage Check Valve
- c - Gasket
- d - Screws
- e - First Stage Check Valve

**NOTE:** Removal of the second stage check valve may cause permanent damage to the pump body, therefore, if replacement is necessary it may be necessary to replace the pump body.

7. Replace bowl gasket, fuel pump body gasket, and center check valve gasket.

**IMPORTANT:** Replace all worn and/or damaged parts.

## Assembling and Installing Fuel Pump

1. Install booster spring and retainer.
2. Position diaphragm and gasket on pump body.

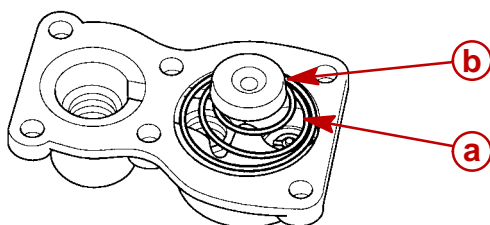

- a - Spring
- b - Retainer

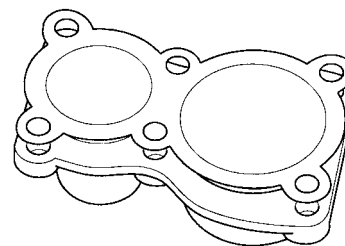



3. Compress spring using a putty knife. Install screws in pump body.
4. Install spacer plate, nuts and gasket.

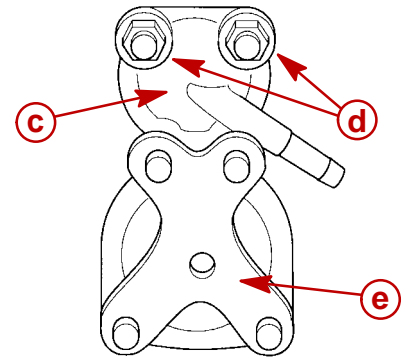
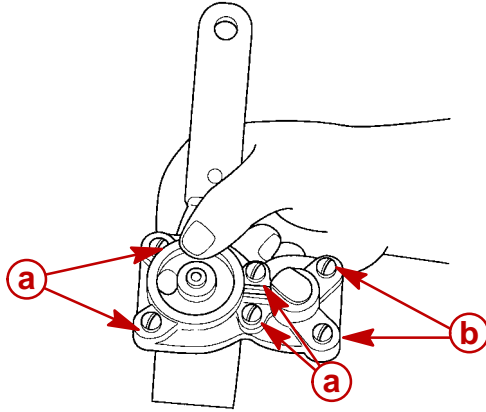

- a** - Long Screws
- b** - Short Screws
- c** - Spacer Plate
- d** - Nuts
- e** - Gasket

5. Position fuel pump assembly on transfer port cover. Tighten screws securely.
  - Apply sealant (p/n 92-90113--2) to threads of fitting. Install fitting.
6. Install fuel hoses.

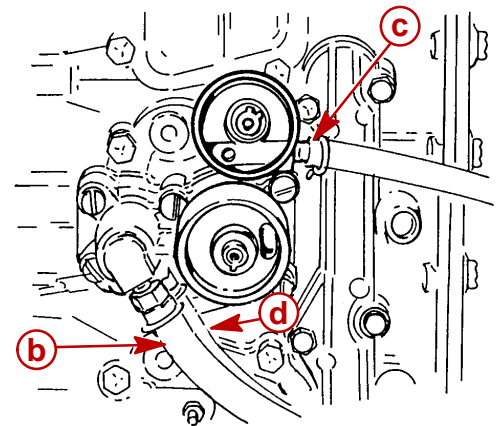
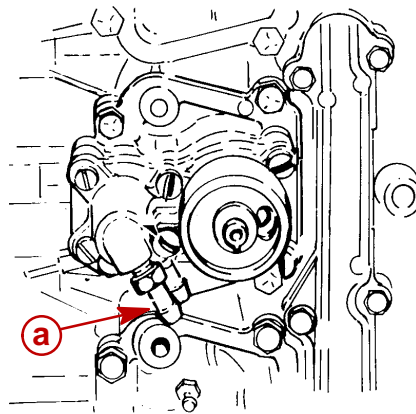

- a** - Fitting
- b** - Fuel Outlet Hose
- c** - Fuel Inlet Hose Connected to Sediment Bowl
- d** - Pulse Hose

7. Install screen in sediment bowl. Install sediment bowl on fuel pump.

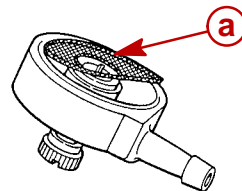

- a** - Screen - Edge Turned Toward Engine



8. Install gasket on pump body.

**IMPORTANT: Position sediment bowl with hose fitting at the 4 o'clock position.**

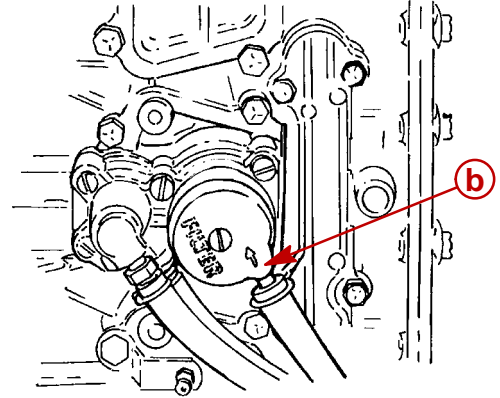
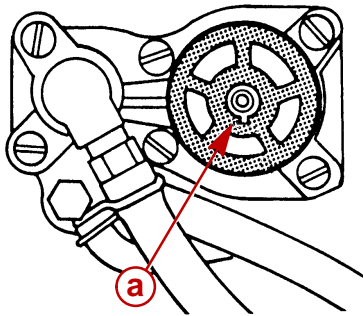

- a** - Gasket, Aligned On Pump Body Keyway
- b** - Hose Fitting At 4 O'Clock Position

## Fuel Pump Exploded View

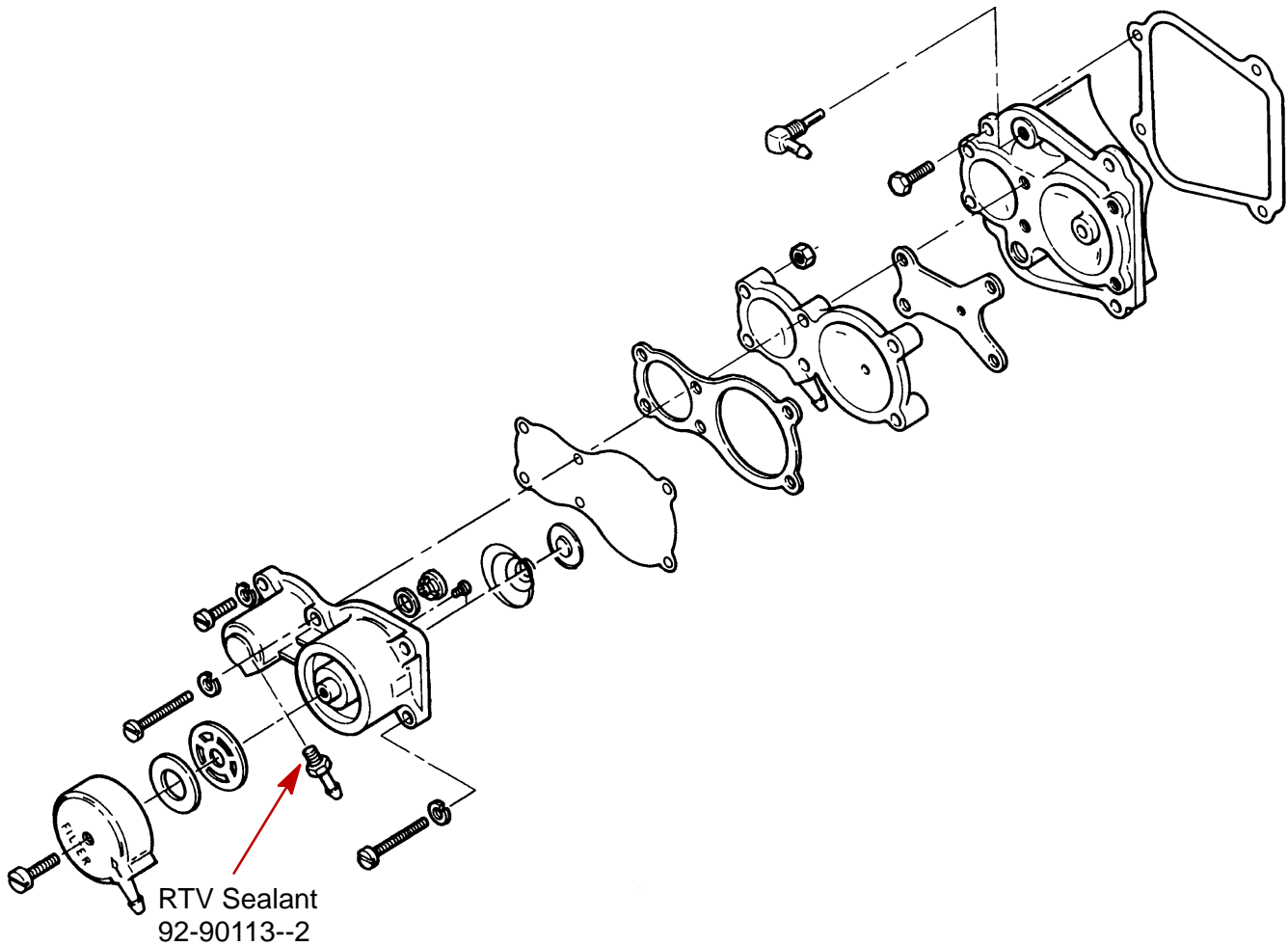



# Fuel Recirculation System

## System Description

At idle, unburned fuel collects and puddles in the crankcase behind the reed valves. The recirculation system is a means to route this excess, unburned fuel back to the combustion chamber.

One way check valves are located on the crankcase cover, typically below the carburetors. Crankcase pressure forces the puddled fuel through the check valves. A hose connected to the check valve routes the fuel to the transfer port cover, whereby the fuel is introduced back to the combustion chamber.

## Testing Fuel Recirculation System

1. Test for proper air flow through check valves as indicated by arrows.

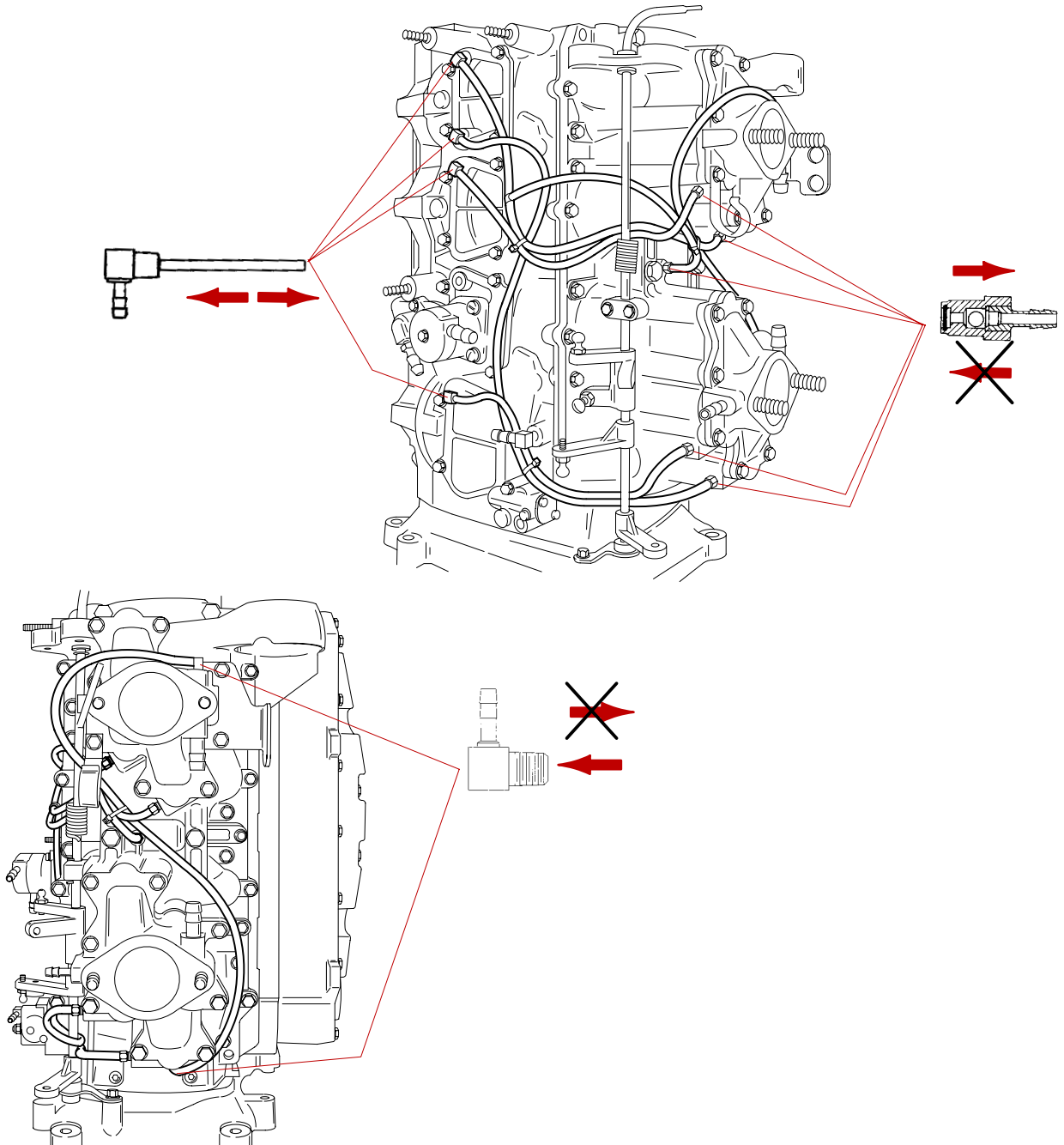



# Reed Valve Assembly

## Removing and Inspecting Reed Valve Assembly

### **WARNING**

**Always disconnect battery and remove spark plug leads from spark plugs before working on motor.**

1. Remove attenuator cover.
2. Remove carburetors.

SEE CARBURETOR SECTION FOR MORE INFORMATION

3. Remove auto enricher.
4. Remove recirculation hose from manifold.
5. Remove bolts securing manifold assembly to crankcase cover.
6. Remove manifold assembly from cylinder block.
7. Remove reed block assembly from reed plate adaptor.





## Inspecting and Installing Reed Block Assembly

1. Inspect reeds for any chipping or cracking.

**NOTE:** The reeds are not serviceable, replace reed block assembly if any discrepancies are found.

2. Inspect reed opening. Replace reed block assembly if reed is standing open more than .020" (.508 mm).

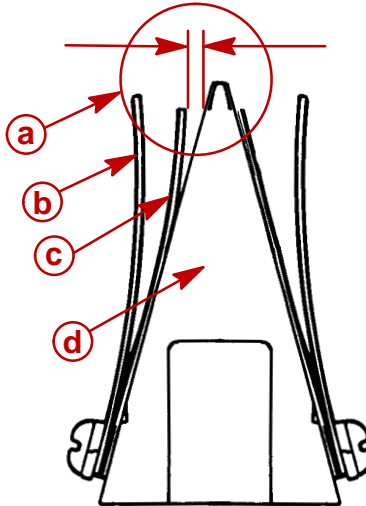

- a** - Maximum Opening .010" (.254 mm)
- b** - Reed Stop
- c** - Reed
- d** - Reed Block

3. Clean all gasket surfaces.
  4. Using new gaskets, install reed block assembly to reed plate adaptor.
  5. Using new gasket, install manifold and reed plate assembly into cylinder block. Secure assembly to cylinder block with screws.
  6. Install auto enrichner.
  7. Install recirculation hose to manifold.
  8. Install carburetors.
- SEE CARBURETOR SECTION FOR MORE INFORMATION
9. Install attenuator cover.



# Reed Plate, Adaptor Plate and Auto Enrichner

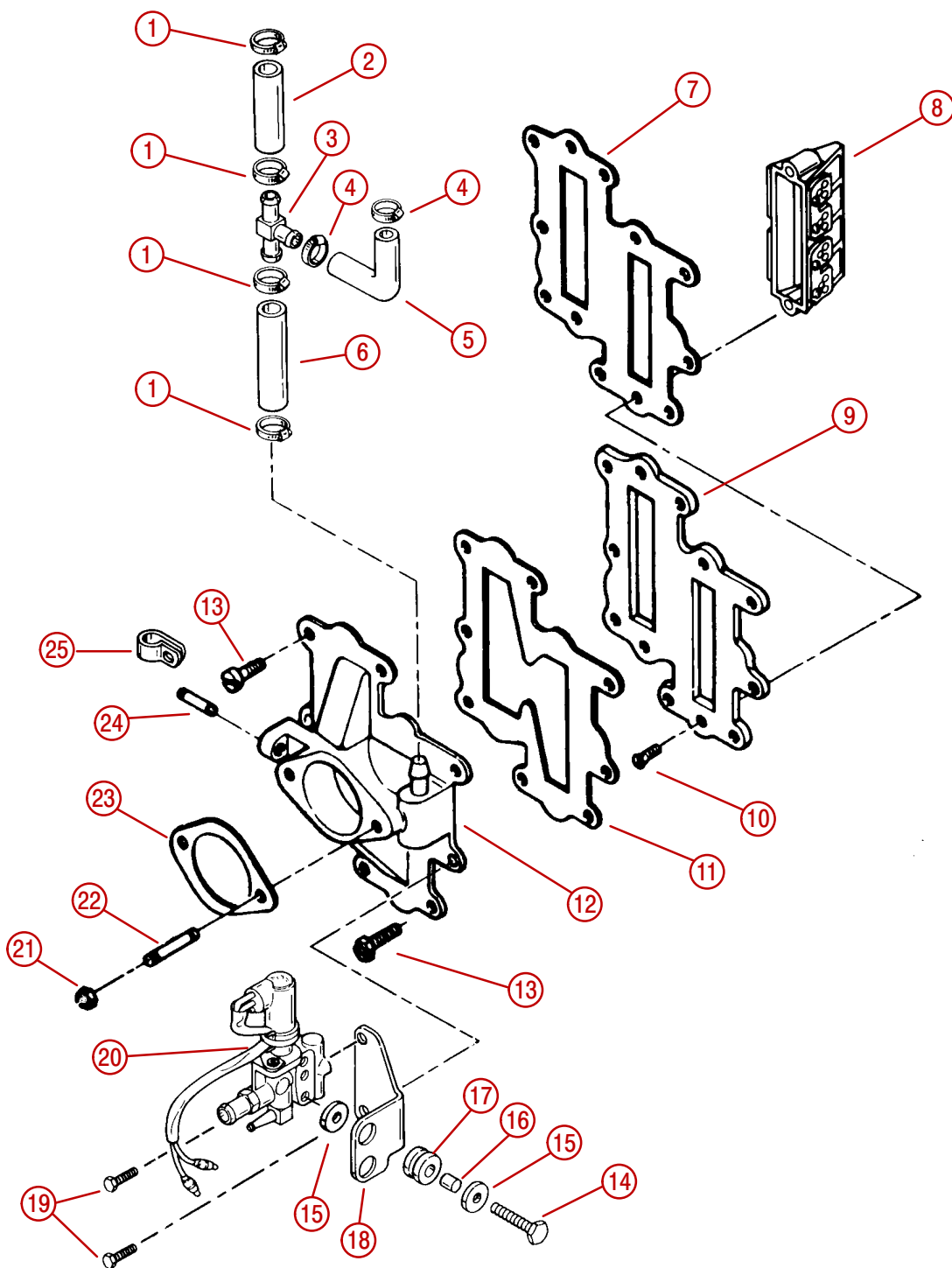



Item	Qty.	Description	Torque		
			Lb. In.	Lb. Ft.	N·m
1	4	Clamp			
2	1	Hose (2-1/4 in.)			
3	1	Fitting			
4	2	Clamp			
5	1	Hose, Molded			
6	1	Hose (2-3/4 in.)			
7	1	Gasket			
8	4	Reed Plate Assembly			
9	1	Plate			
10	8	Screw (1/4-20 x 5/8 in.) With Dri Loc			
11	1	Gasket			
12	1	Adapter Assembly (Upper) <i>Lower Adapter Not Shown</i>			
13	14	Screw (1/4-20 x 7/8 in.)			
14	2	Screw (M6 x 30)			
15	2	Washer			
16	2	Bushing			
17	2	Grommet			
18	1	Bracket			
19	2	Screw (1/4-20 x 1-1/4 in.)			
20	1	Auto Enrichner			
21	4	Nut (3/8-16)			
22	4	Stud (3/8-16 x 1-5/8 in.) With Dri Loc			
23	2	Gasket			
24	1	Stud (1/4-20 x 1 in.) With Dri Loc			
25	1	Clamp			

## Auto Enrichner

### System Description

The Sport Jet utilizes an automatic enrichner to start the engine. The auto enrichner is a self contained unit with three hose connections to allow for 1) fuel inlet, 2) air inlet, 3) fuel/air mixture outlet.

Fuel is supplied to the auto enrichner by a hose connection to the carburetor float bowl. Air is supplied to the valve by a hose connection to the sound attenuator.

When the engine is cranked a fuel/air mixture is drawn into the engine from the auto enrichner by a hose connection to the balance tubes. The carburetor shutters must be completely closed for the engine to draw the fuel/air mixture from the auto enrichner.



A wax pellet controls the position of a slide valve and tapered needle. The stator supplies electrical current to a heater element inside the auto enricher. As the heater element melts the wax pellet the fuel/air mixture is slowly closed off by the slide valve/tapered needle. The engine continues to run from the fuel/air mixture supplied by the carburetor idle circuit.

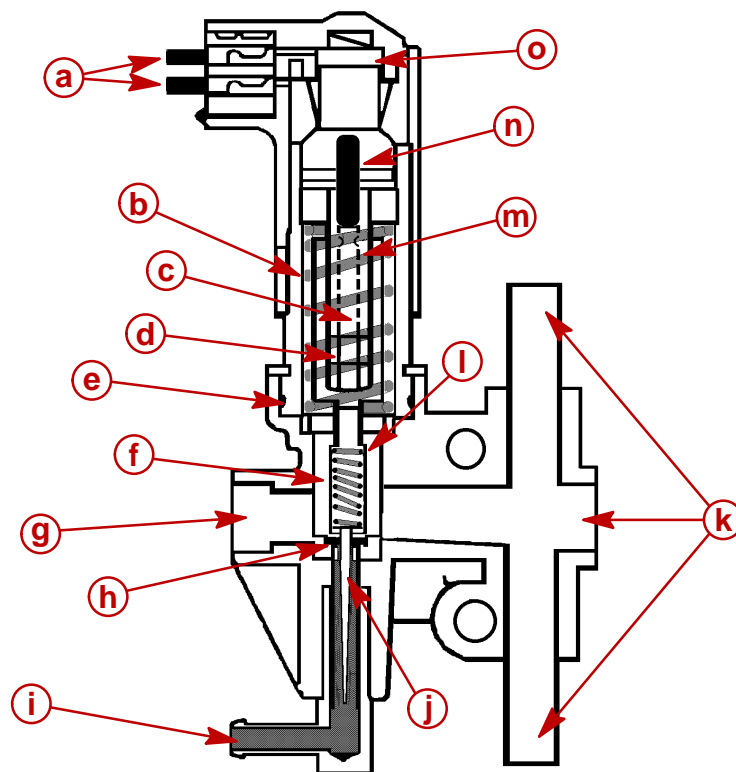

- a** - Stator Leads (Yellow)
- b** - Return Spring
- c** - Actuator Rod
- d** - Plastic Spring Guide
- e** - O-ring
- f** - Slide Valve
- g** - Air Inlet
- h** - Rubber Seat
- i** - Fuel Inlet
- j** - Tapered Needle
- k** - Fuel/Air Mixture Outlet (Not All Outlets Are Used)
- l** - Compensating Spring
- m** - Brass Guide
- n** - Wax Pellet
- o** - Heater Element

## Testing Auto Enrichner

On a cold engine the tapered needle will move from full open to full closed after approximately 2 - 2.5 minutes of engine running.

On a cold engine resistance between the two yellow leads is 18 - 20 ohms. As the engine warms up the resistance reading will approach infinity.