

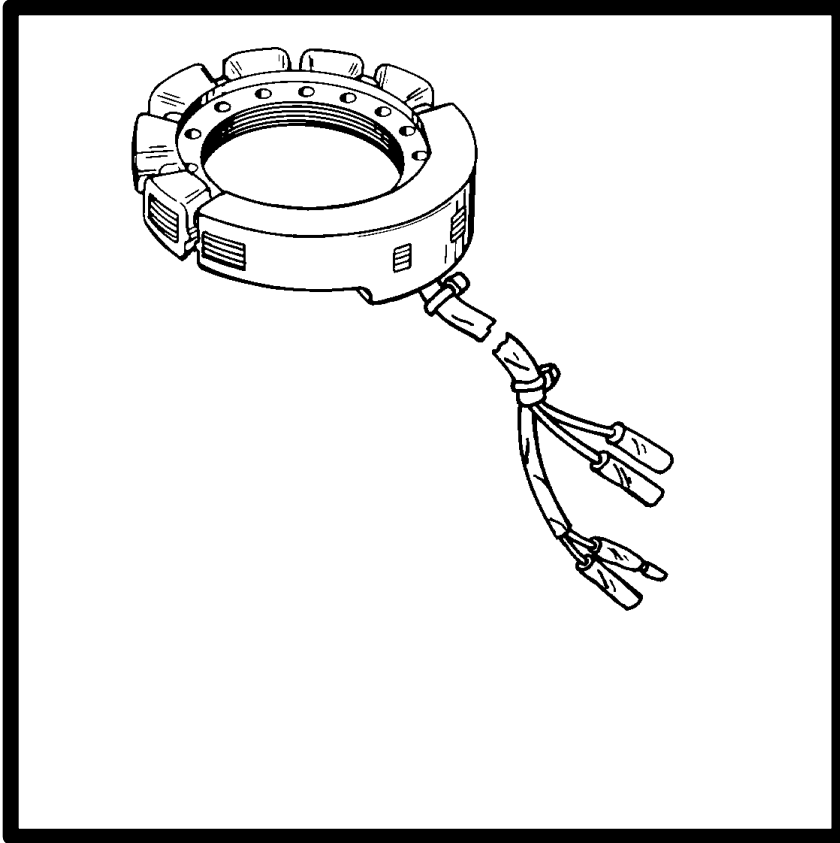

ELECTRICAL AND IGNITION



IGNITION SYSTEM

2

A



Table Of Contents

	Page
Special Tools Required	2A-1
General	2A-1
Principles of Operation	2A-1
Test Procedures	2A-1
Testing For Spark	2A-2
Testing Primary Input Voltage	2A-2
Test Switch Box "Stop" Circuit.	2A-3
Testing Stator Output	2A-3
Testing Stator Resistance	2A-3
Testing Switch Box Bias Circuit- 90 HP Only	2A-4
Testing Trigger Resistance	2A-4
Testing Ignition Coils	2A-5
Erratic/Misfire or No Fire Condition	2A-6

	Page
Removing Flywheel	2A-7
Installing Flywheel	2A-8
Removing Stator	2A-8
Installing Stator	2A-8
Removing Trigger	2A-8
Installing Trigger	2A-9
Removing Switch Box	2A-9
Installing Switch Box	2A-9
Removing Coils	2A-10
Installing Coils	2A-10
Ignition Diagram 90 HP Sport Jet	2A-11
Ignition Wiring Diagram 120 Sport Jet	2A-12



Special Tools Required

Multimeter/ DVA Tester 91-99750

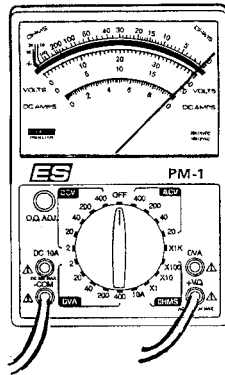

Spark Tester 91-850439

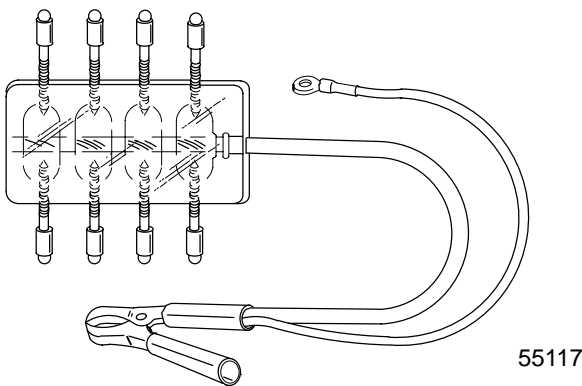

General

The ignition system used on the Sport Jet engines is self-energizing (creates it's own power for ignition) and has proven reliability. Should testing be required it is important to check all components in the order outlined.

IMPORTANT: Read the entire procedure before attempting to test components.

The procedures in this section are designed to test the complete ignition system. In an actual situation test only the components that control the misfiring cylinder(s).

⚠ WARNING

When testing or servicing the ignition system high voltage is present; be extremely cautious! DO NOT TOUCH OR DISCONNECT any ignition components while engine is cranking or running.

Principles of Operation

The ignition system is alternator driven with distributorless capacitor discharge. Major components of the ignition system are the flywheel, stator, trigger, switch box, ignition coils and spark plugs.

The stator assembly is mounted stationary below the flywheel and has two capacitor charging coils. The flywheel is fitted with permanent magnets inside the outer rim. As the flywheel rotates the permanent magnets pass the capacitor charging coils. This causes the capacitor charging coils to produce AC voltage. The AC voltage then is conducted to the switch box where it is rectified and stored in a capacitor.

The trigger assembly (also mounted under the flywheel) has 2 coils. The flywheel likewise has a second set of permanent magnets (located around the center hub). As the flywheel rotates the second set of magnets pass the trigger coils. This causes the trigger coils, in turn, to produce an AC voltage that is conducted to an electronic switch (SCR) in the switch box.

The switch discharges the capacitor voltage into the primary side of the ignition coil.

The ignition coil multiplies this voltage to a value high enough to jump the gap at the spark plug.

The preceding sequence occurs once per engine revolution for each cylinder.

Spark timing is changed (advanced/retarded) by rotating the trigger assembly which changes each trigger coil position in relation to the permanent magnets on the flywheel hub.

Test Procedures

⚠ WARNING

When testing or servicing the ignition system high voltage is present. Be extremely cautious! DO NOT TOUCH OR DISCONNECT any ignition parts while engine is running, while key switch is on, or while battery cables are connected.

⚠ CAUTION

Failure to comply with the following items may result in damage to the ignition system.

- DO NOT reverse battery cable connections. The battery negative cable is (–) ground. DO NOT “spark” battery terminals with battery cable connections to check polarity.
- DO NOT disconnect battery cables while engine is running.
- DO NOT crank engine when switch box is not grounded to engine.

The switch box cannot be thoroughly checked with conventional test equipment. If a Multimeter/DVA Tester is not used systematically check the switch box.



All other components can be tested with an ohmmeter. Before troubleshooting the ignition system:

- Make sure the electrical harness and ignition switch are not the source of the problem.
- Check that plug-in connectors are fully engaged and terminals are free of corrosion.
- Make sure that wire connections are tight and free of corrosion.
- Check that all electrical components and separate ground wires are grounded directly to engine.
- Check for disconnected wires, short and open circuits.

Testing For Spark

1. Adjust spark tester to a 7/16" gap setting.

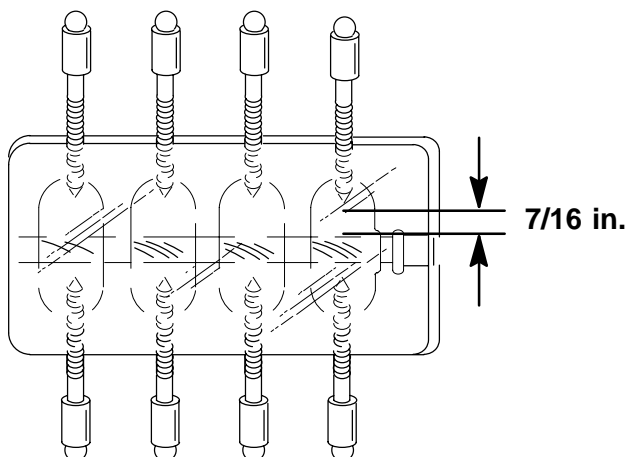

2. Secure spark tester to a good engine ground.
3. Remove leads from spark plugs.
4. Connect spark plug leads to corresponding spark tester leads.
5. Remove spark plugs.

Engine must be able to crank at 600 RPM minimum for the following tests.

6. Crank motor.

Results:	Action Required:
Spark jumps 7/16 in. gap (all cylinders)	Ignition system is operational, check timing sequence if required
No spark	Go to next step

7. Check all grounds and wire connections.

Repair as needed.

8. Recheck spark output.

Check that safety stop switch lanyard is in place. If safety lanyard is NOT in place, spark plugs will not fire.

9. Isolate the stop circuit by disconnecting black/yellow bullet connector from the switch box.

IMPORTANT: Be sure this lead is not grounded.

10. Crank motor.

Results:	Action Required:
All cylinders spark normally	Repair stop circuit: ignition key switch and/or boat wiring.
No spark	Go to next step

Testing Primary Input Voltage

1. Prepare multimeter.
 - Plug meter leads in as shown.
 - Set dial to 400 DVA scale.

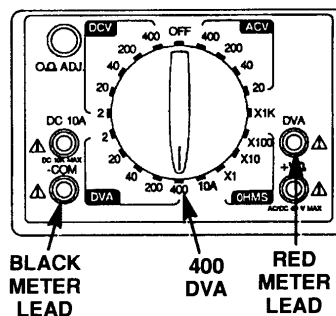

2. Connect red meter lead to #1 coil (+) terminal.
3. Connect black meter lead to #1 coil (-) terminal.

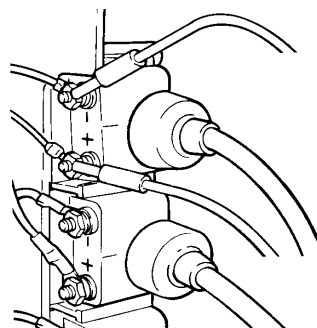

4. Crank motor and observe meter.
5. Repeat test for each coil.

IMPORTANT: DO NOT use a common ground. Connect black meter lead to the ground of coil being tested.

Results:	Action Required:
150 - 250 volts	Go to Testing Coils
Less than 150 volts	Go to Next Step



Test Switch Box “Stop” Circuit.

1. Prepare multimeter as shown.

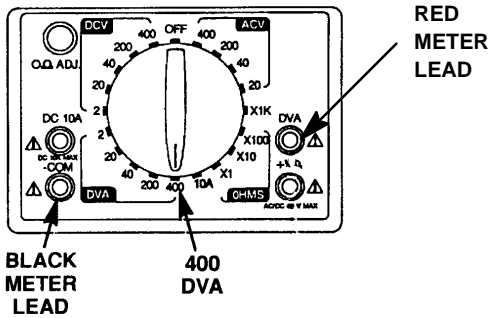

- Disconnect black/yellow lead from switch box.
 - Attach red meter lead to black/yellow lead from switch box.
 - Attach black meter lead to ground.
2. Crank motor and observe meter.

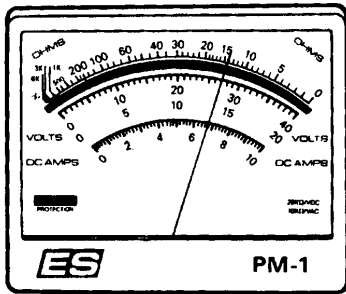

Results:	Action Required:
200-360 volts	Go to Testing Trigger. If checks O.K., replace switch box.
Less than 200 volts	Go to next step

Testing Stator Output

IMPORTANT: All leads must remain connected to the switch box for the following DVA tests.

1. Stator low speed input to switch box.
 - Connect red meter lead to blue lead from stator.
 - Connect black meter lead to a good engine ground.
 - Set meter to 400 DVA scale.

2. Crank motor while reading meter.

90 and 120 HP	
Results:	Action Required:
200-300 volts	Low speed stator is O.K.: Go to Testing Trigger
Less than 200 volts or intermittent	Go to next step. If stator tests O.K., replace switch box.

3. Stator high-speed input to switch box.

- Connect red meter lead to red stator lead.
- Connect black meter lead to a good ground.
- Set meter to 400 DVA scale.

4. Crank motor while reading meter.

90 and 120 HP	
Results:	Action Required:
20-90 volts	High speed stator is O.K.: Go to Testing Trigger.
Less than 20 volts or intermittent	Go to next step

Testing Stator Resistance

1. Prepare multimeter (Special Tool No. 91-99750).

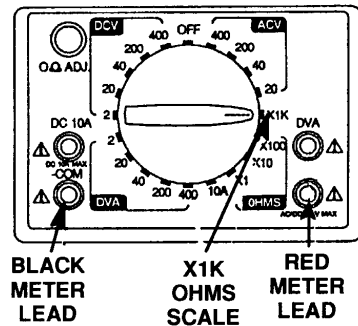

- Plug in meter leads as shown.
- Set dial to X1K ohm position.
- Calibrate meter.

2. Low speed resistance test.

NOTE: This test is not polarity sensitive.



90 HP:

- Disconnect blue and red stator leads from switch box.
- Connect meter leads between blue and red stator leads.

Results:	Action Required:
3600 - 4200* ohms	Go to next test
Above or below 3600 - 4200 ohms	Replace stator

*Copper is an excellent conductor, but resistance may notably vary between low and high temperature. Therefore, reasonable differences can be accepted between resistance readings and specifications.

120 HP:

- Disconnect blue and blue/white stator leads from switch box.
- Connect meter leads between blue and blue/white stator leads.

3. Observe meter reading.

Results:	Action Required:
6800 - 7600* ohms	Go to next test
Above or below 6800 - 7600 ohms	Replace stator

*Copper is an excellent conductor, but resistance may notably vary between low and high temperature. Therefore, reasonable differences can be accepted between resistance readings and specifications.

4. High speed resistance test.

- Set meter scale to X1 ohm.

90 HP:

- Disconnect red stator lead from switch box.
- Connect meter leads between red and engine ground (if stator has been removed from engine connect meter leads between red stator lead and stator ground).

120 HP:

- Disconnect red and red/white stator leads from switch box.
- Connect meter between red stator lead and red/white stator leads.

5. Observe meter reading.

Results:	Action Required:
90 - 140 ohms	Stator O.K., continue electrical testing
Above or below 90 - 140 ohms	Replace stator

Testing Switch Box Bias Circuit- 90 HP Only

1. Prepare multimeter as shown.

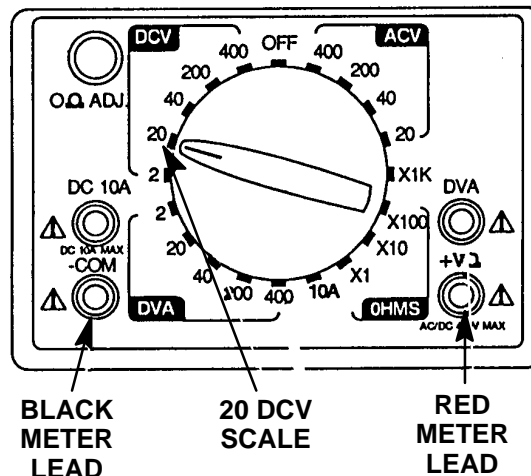

NOTE: White/black lead must remain connected to switch box for this test.

- Attach Black meter lead to white/black lead from switch box.
 - Attach Red meter lead to ground.
2. Crank motor and observe meter reading.

Results:	Action Required:
2 - 10 volts	Go to testing Trigger. If trigger tests O.K. replace switch box.
Below 2 volts	Replace switch box.

Testing Trigger Resistance

1. Prepare multimeter.
- Plug meter leads in as shown.
- Set dial to x100 ohm.
- Calibrate meter.

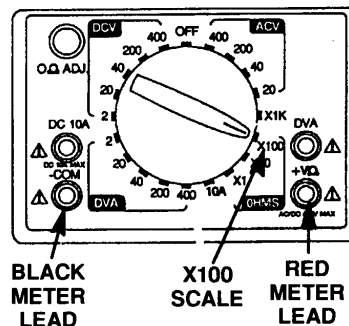



- Disconnect trigger leads. Test resistance between trigger leads as shown in the following chart.

This test is not polarity sensitive.

90 HP	
Meter Leads	Meter Reading
Between Brown and White/Black	1100 - 1400 Ohms
Between White and White/Black	
Between Violet and White/Black	
120 HP	
Meter Leads	Meter Reading
Between Violet and White	700 - 1000 Ohms
Between Brown and White/Black	

*Copper is an excellent conductor, but resistance may notably vary between low and high temperature. Therefore, reasonable differences can be accepted between resistance readings and specifications.

- Replace trigger as necessary.

Testing Ignition Coils

- Check primary resistance.

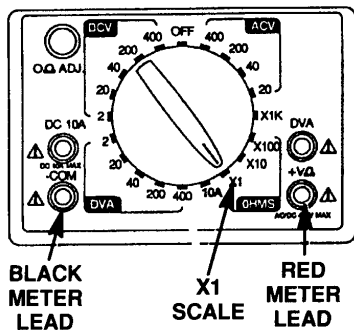

- Prepare multimeter as shown.
 - Set dial to X1 scale.
 - Calibrate meter
 - Disconnect coil input leads.
- Connect meter leads.

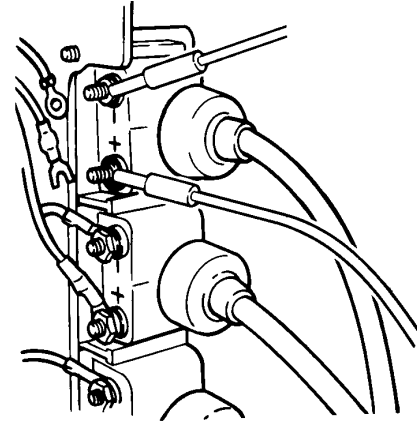

- Red meter lead to #1 coil (+) terminal.
- Black meter lead to #1 coil (-) terminal.

This test is not polarity sensitive.

- Observe meter.

Results:	Action Required:
.02 - .04* ohms	Go to next step
Above or below .02 - .04 ohms	Replace coil
*The primary DC resistance of these coils generally is less than one ohm. If a reading resembling a short is obtained, this would be acceptable.	

- Repeat test for each coil.
- Check secondary resistance.
 - Remove spark plug wire from coil tower.
 - Set dial to X100 scale.
 - Calibrate meter.



- Connect meter leads between coil tower and coil positive (+) terminal.

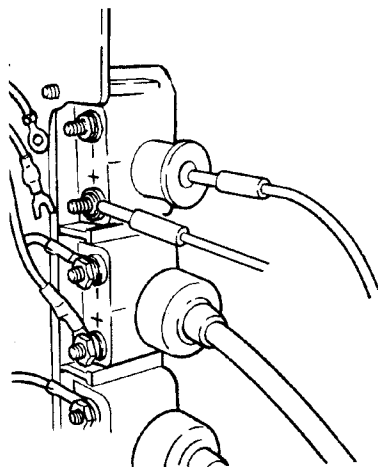

- Observe meter reading.

Results:	Action Required:
800 - 1100*	Go to next section
Above or below 800 - 1100 ohms	Replace coil

*Copper is an excellent conductor, but resistance may notably vary between low and high temperature. Therefore, reasonable differences can be accepted between resistance readings and specifications.

Erratic/Misfire or No Fire Condition

Occasionally a problem may occur that will not show when testing at cranking speed. Some tests can be performed with the engine running at the particular RPM when the problem occurs.

“Running” tests use the same procedures as “cranking” tests. Refer to the chart following for running test readings.

Test	Selector Position	DVA Leads		Voltage Reading @ 300-1000 RPM ⁽¹⁾	Voltage Reading @ 1000-4000 RPM
		Red	Black		
Coil Primary	400VDC*	Coil (+) Terminal	Coil (-) Terminal	150-250	180-280
Sw. Box - Stop circuit	400VDC*	Black/Yellow Sw. Box Connector	Ground	200-360	200-360
Stator - Low Speed	400VDC*	Blue Sw. Box Connector	Ground	200-300	200-330
Stator - High Speed	400VDC*	Red Sw. Box Connector	Ground	20-90	130-300

*If using a meter with a built-in DVA, place selector in the DVA/400 VDC position.

⁽¹⁾Readings at cranking speed and/or idle speed.



Removing Flywheel

⚠ WARNING

Always disconnect battery and remove spark plug leads from spark plugs before working on motor.

1. Remove flywheel nut.

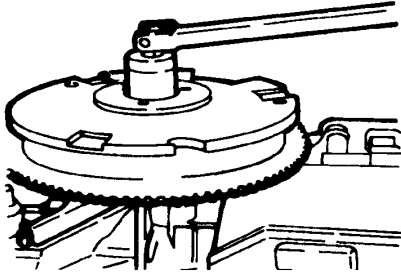

Use a suitable flywheel holder to keep flywheel from turning.

2. Install puller (Special Tool No. FT-8948-1).

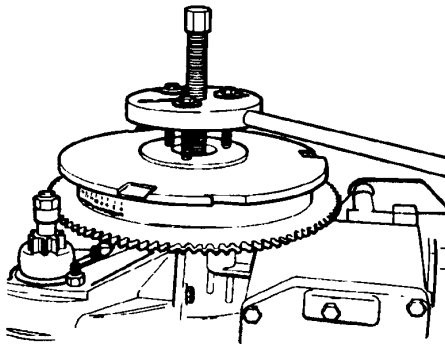

Perform the following step while holding the puller bar. This will prevent the puller plate from turning.

3. Turn pressure screw until it is tight against the crankshaft.

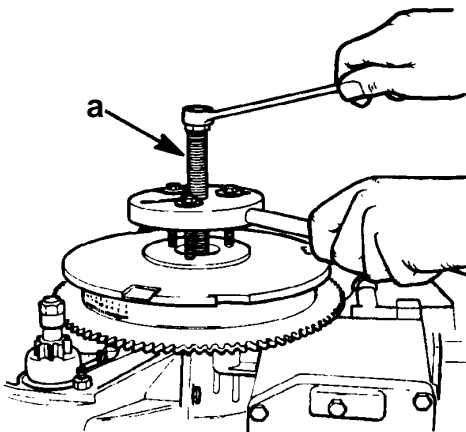

a - Pressure Screw

⚠ CAUTION

Do not strike the screw too hard. This may damage the crankshaft and bearings.

4. Strike top of pressure screw (a) with hammer.

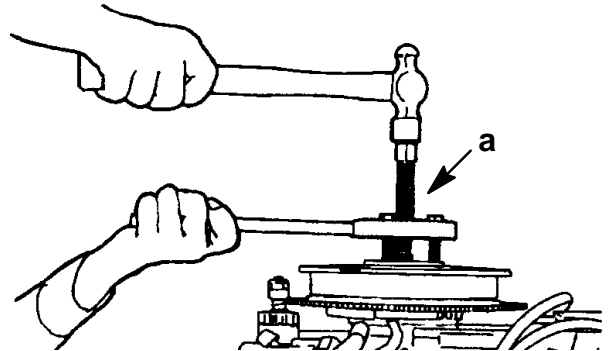

5. Remove flywheel from crankshaft.

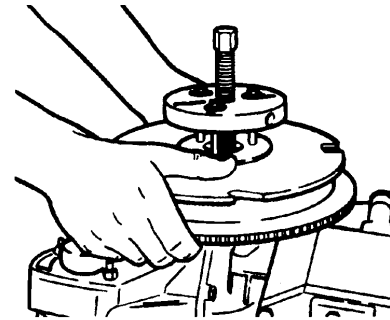

6. Remove puller from flywheel.
7. Remove flywheel key.

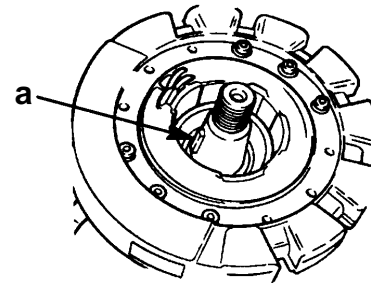

a - Flywheel Key

8. Inspect flywheel.
 - Carefully inspect flywheel for cracks or damage.

⚠ WARNING

A cracked or chipped flywheel must be replaced. At high RPM a damaged flywheel may fly apart and throw metal over a large area.

- Inspect crankshaft and flywheel tapers for worn or damaged key ways.



- Check for loose magnet or damaged timing magnet laminations.

Arc burns on timing magnet laminations are normal.

- Replace flywheel if necessary.

Installing Flywheel

1. Clean tapered surfaces of flywheel and crankshaft with solvent.

- Blow dry tapered surfaces with compressed air.

If the flywheel key appears damaged in any way replace it.

2. Install flywheel key in crankshaft slot with outer edge of key parallel to center line of crankshaft.

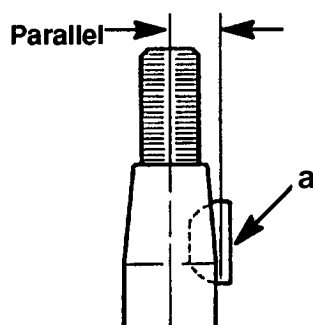

a - Flywheel Key

3. Install flywheel.

- Place flywheel down over crankshaft.
- Install flywheel nut.
- Torque flywheel nut to 125 lb. ft. (169.5 N·m).

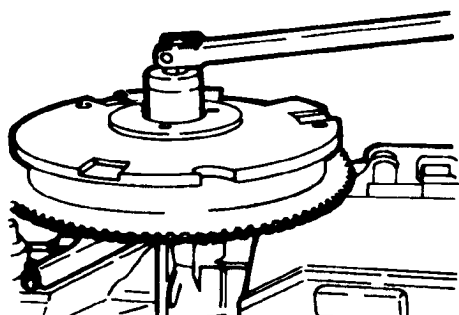

Removing Stator

1. Remove flywheel.

SEE "REMOVING FLYWHEEL" IN THIS SECTION.

2. Remove yellow stator leads from rectifier/regulator leads.

3. Disconnect all stator leads from switch box leads.

Removal of switch box mounting bracket may be necessary to gain access to stator leads.

4. Remove screws and lift stator off bearing cage.

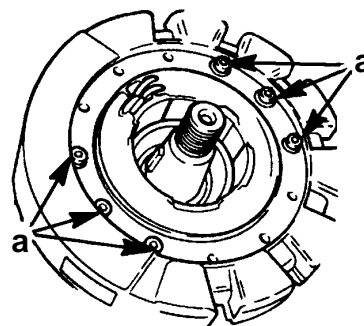

a - Stator Screws

Installing Stator

1. Set stator on bearing cage. Secure with screws.

IMPORTANT: Be sure the stator is positioned so the wire harness is on the port side of the motor.

2. Connect yellow stator leads to yellow rectifier/regulator leads.
3. Connect all stator leads to corresponding switch box leads.
4. Install flywheel.

Removing Trigger

1. Remove flywheel.

SEE "REMOVING FLYWHEEL" IN THIS SECTION.

2. Remove stator.

SEE "REMOVING STATOR" IN THIS SECTION.

3. Disconnect all trigger leads from switch box leads.
4. Disconnect spark control link from tower shaft.
5. Lift trigger off bearing cage.

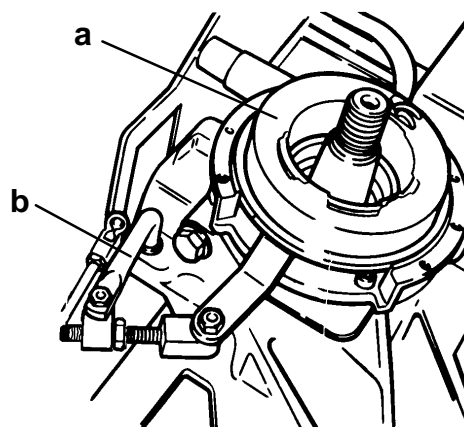

a - Trigger

b - Spark Control Link



Installing Trigger

1. Install spark control link on new trigger.

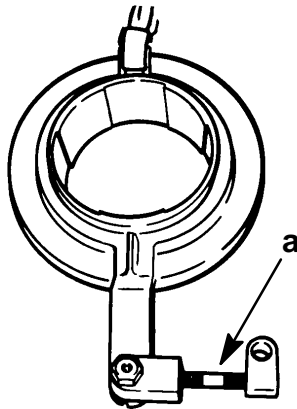

a - Spark Control Link

2. Lubricate outer ring of trigger with grease.
3. Place trigger on bearing cage.
4. Secure spark control link to towershaft.

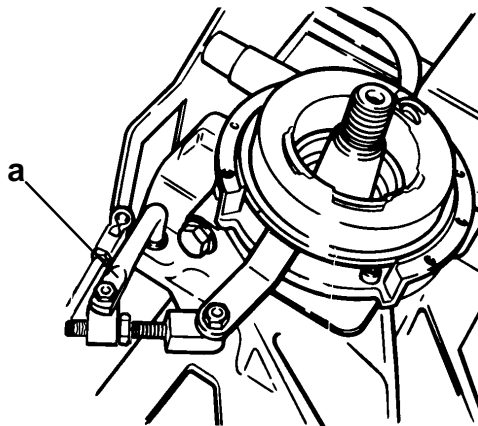

a - Towershaft

5. Route lead wires under ignition harness guard and down to switch box.
6. Connect corresponding trigger leads to switch box leads:
7. Install stator.

SEE INSTALLING STATOR IN THIS SECTION.

8. Install flywheel.

SEE INSTALLING FLYWHEEL IN THIS SECTION.

9. Check engine timing.

SEE ENGINE TIMING IN THIS SECTION.

Removing Switch Box

⚠ WARNING

Always disconnect battery and disconnect spark plug leads from spark plugs before working on motor.

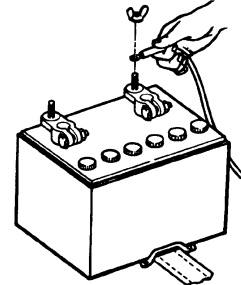

1. Remove three screws and clamp.
2. Remove switch box from bracket.
3. Remove lead wires from switch box.

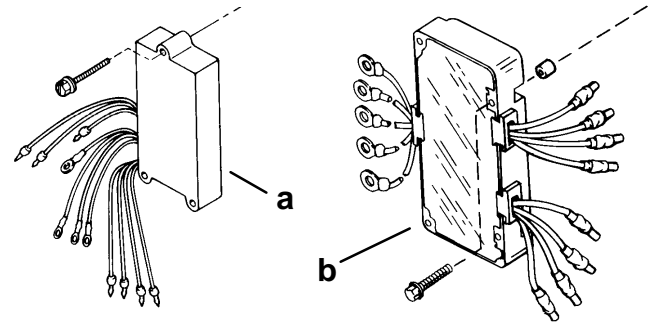

a - 90 HP Switch Box

b - 120 HP Switch Box

Installing Switch Box

1. Position switch box on bracket.
2. Install screws and clamp.

The clamp is attached with the lower forward mounting screw.

3. Attach lead wires.

Switch box leads are identified by color.

Stator Leads	Red, Blue, Red/White, Blue/White
Coil Leads	Green, Green/White, Green/Red, Green/Black
Stop Lead	Black/Yellow
Trigger Leads	Brown, Violet, White, White/Black



Removing Coils

⚠ WARNING

Always disconnect battery and disconnect spark plug leads from spark plugs before working on motor.

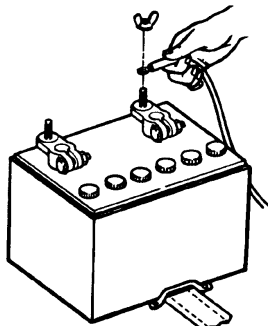

1. Remove screws holding coil cover.

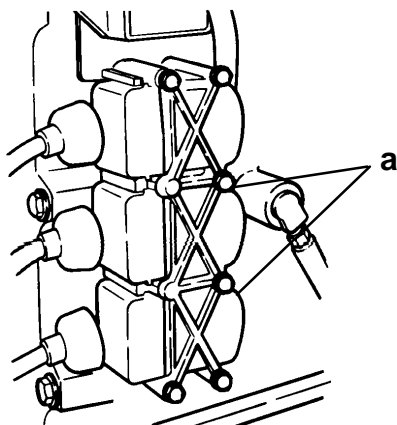

a - Screw

2. Remove coil/cover assembly from bracket.
3. Remove coil input wire (+) and ground wire (-) from coil.
4. Slide coil out of cover.

NOTE: Coils are serviced individually.

Installing Coils

1. Attach wires to coil:
 - #1 Green
 - #2 Green/White
 - #3 Green/Red
 - #4 Green/Black (120 HP)

Positive (+) terminal is down.

2. Position coil/cover assembly on bracket.

NOTE: 90 HP shown

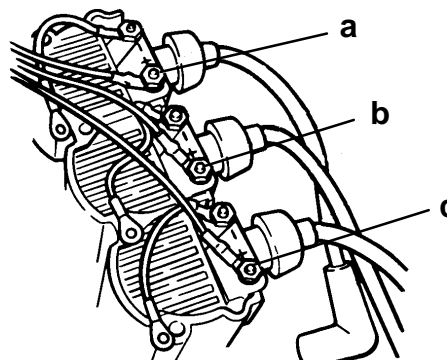

- a - #1 Green Terminal
- b - #2 Green/White Terminal
- c - #3 Green/Red Terminal

3. Slide coil into cover.
4. Position coil/cover assembly on bracket.
5. Install cover screws, tighten all fasteners.



Ignition Diagram 90 HP Sport Jet

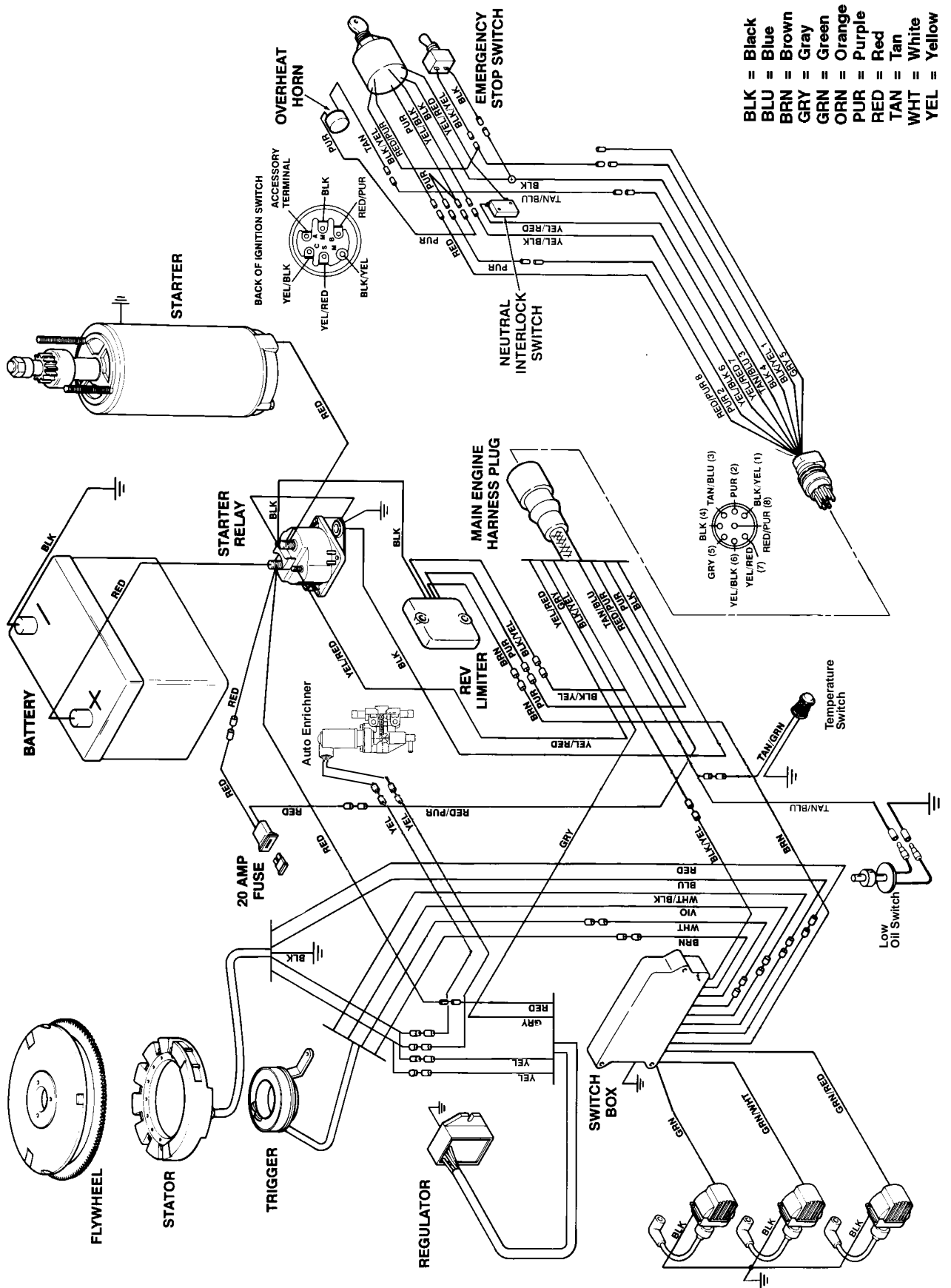



Ignition Wiring Diagram 120 Sport Jet

