



ATTACHMENTS/CONTROL LINKAGE

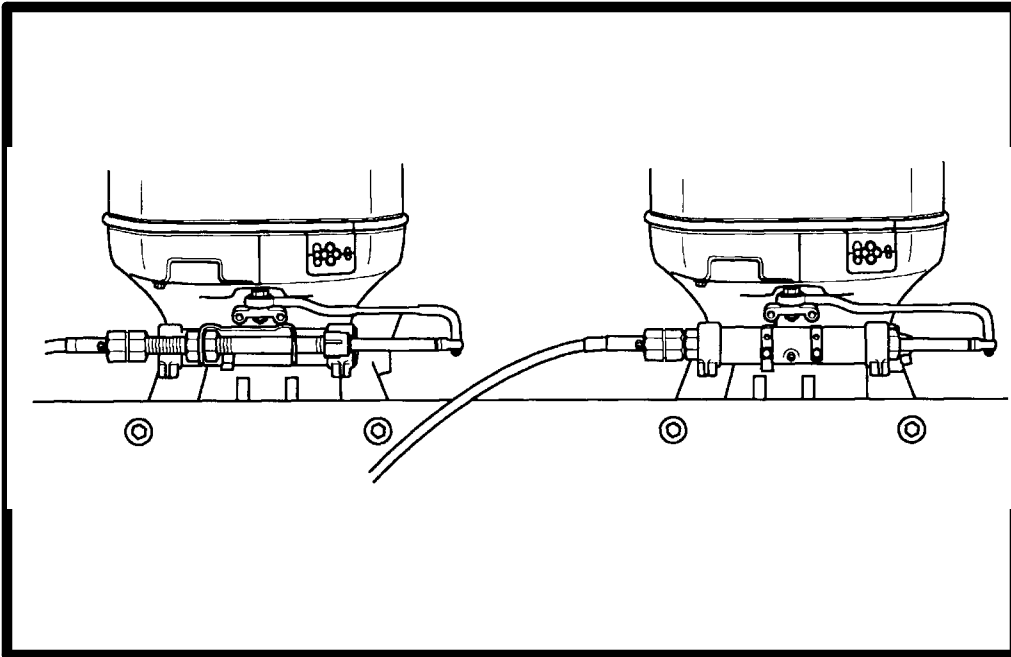



Table of Contents

	Page
Ride Guide Steering Cable/Attaching Kit Installation (92876A1)	7-1
Single Cable -	7-1
Maintenance Instructions	7-2
Ride Guide Steering Cable/ Attaching Kit Installation (92876A3)	7-3
Dual Cable - Single Outboard	7-3
Super Ride-Guide Steering Kit Installation	7-3
Steering Cable Mounting Tube Installation	7-4
Installing Steering Cables	7-4
Coupler Installation	7-5
Installing Link Rod	7-5
Maintenance Instructions	7-7
Ride Guide Steering Cable/ Attaching Kit Installation (92876A6)	7-8
Dual Cable - Dual Outboard	7-8
Installation Requirements	7-8
Parallel Routed Steering Cables and Attaching Kit Installation	7-9
Opposite Side Routed Steering Cables and Attaching Kit Installation	7-16
Trim Tab Adjustment	7-22
Ride Guide Steering Attachment Extension Couplers	7-22
Maintenance Instructions	7-23

	Page
Transom Mounted Ride Guide Attaching Kit Installation (73770A1)	7-24
Attaching Kit Installation	7-24
Maintenance Instructions	7-26
Clevis Attaching Kit Installation (A-70599A2)	7-26
Installation Instructions	7-26
Maintenance Instructions	7-27



Ride Guide Steering Cable/ Attaching Kit Installation (92876A1)

Single Cable -

Refer to “**Quicksilver Accessories Guide**” to determine correct length of steering cable and remote control cables.

IMPORTANT: Steering cable and remote control cables must be the correct length, sharp bends on too-short cables result in “kinks”; too-long cables require unnecessary bends and/or loops. Both conditions place extra stress on the cables and will reduce the performance of the steering system.

INSTALLING RIDE GUIDE CABLE TO OUTBOARD TILT TUBE

IMPORTANT: Before installing steering cable in tilt tube, lubricate entire cable end with Quicksilver 2-4-C w/Teflon.

NOTE: Ride Guide steering cable is lubricated at the factory and requires no additional lubrication at initial installation.

1. Lubricate seal (a) inside of outboard tilt tube and entire cable end (b) with Quicksilver 2-4-C w/Teflon.
2. Insert steering cable end thru outboard tilt tube and secure steering cable to tilt tube with steering cable attaching nut (c), as shown. Torque nut to 35 lb. ft. (47.5 N·m).

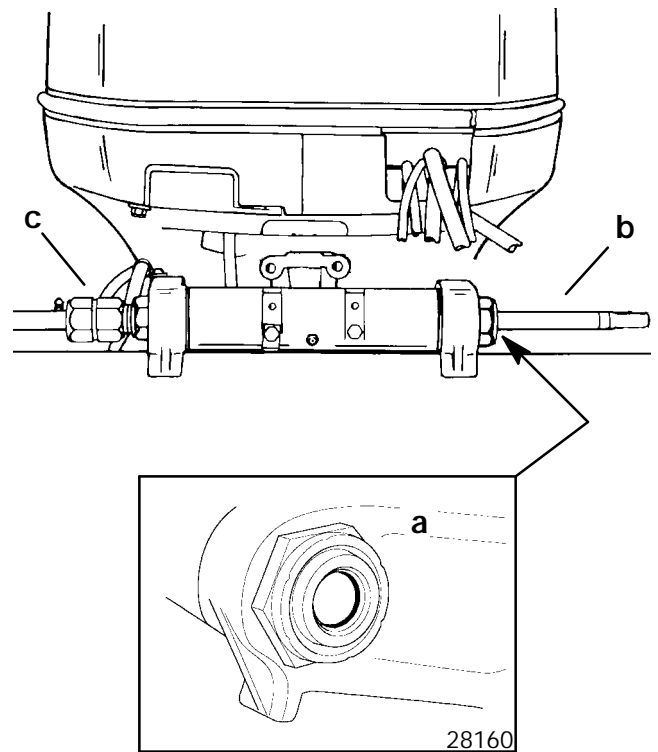



STEERING LINK ROD INSTALLATION

IMPORTANT: The steering link rod that connects the steering cable to the engine must be fastened using special washer head bolt ("a" - Part Number 10-14000) and self locking nuts ("b" & "c" - Part Number 11-34863). These locknuts must never be replaced with common nuts (non locking) as they will work loose and vibrate off freeing the link rod to disengage.

⚠ WARNING

Disengagement of a steering link rod can result in the boat taking a full, sudden, sharp turn. This potentially violent action can cause occupants to be thrown overboard exposing them to serious injury or death.

- Assemble steering link rod to steering cable with two flat washers (d) and nylon insert locknut ("b" - Part Number 11-34863). Tighten locknut (b) until it seats, then back nut off 1/4 turn.
- Production Outboards** - Assemble steering link rod to engine with special washer head bolt ("a" - Part Number 10-14000) and nylon insert locknut ("c" - Part Number 11-34863). First torque bolt (a) to 20 lb. ft. (27.1 N·m), then torque locknut (c) to 20 lb. ft. (27.1 N·m).

High Performance Outboards - An access hole is provided through the bottom cowl to ease installation of the link rod connecting bolt. Remove the **BACK** plug for installation and reinstall after installation.

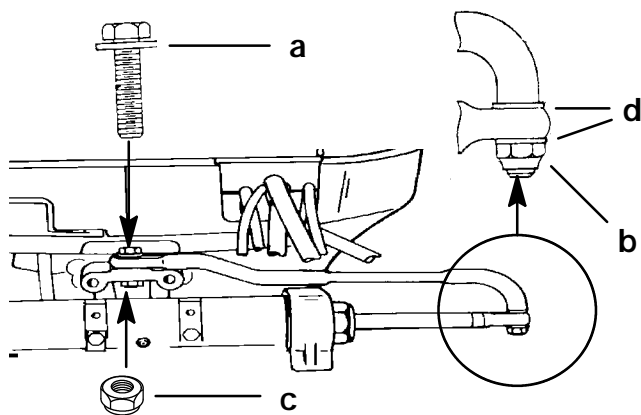

⚠ WARNING

After installation is complete (and before operating outboard), check that boat will turn right when steering wheel is turned right and that boat will turn left when steering wheel is turned left. Check steering thru full range (left and right) and at all tilt angles to assure interference-free movement.

Maintenance Instructions

Maintenance inspection is owner's responsibility and must be performed at intervals specified, following:

Normal Service - Every 50 hrs. of operation or 60 days (whichever comes first)

***Severe Service** - Every 25 hrs. of operation or 30 days (whichever comes first)

*Operation in a salt water area is considered "Severe Service."

- Carefully check steering system components for wear. Replace worn parts.
- Check steering system fasteners to be sure that they are torqued to correct specifications.

NOTE: Ride-Guide Steering Cables are lubricated at the factory and require no additional lubrication at initial installation.

⚠ WARNING

Core of each steering cable (transom end) must be fully retracted into cable housing before lubricating cable. If cable is lubricated while extended, hydraulic lock of cable could occur.

- With core of Ride-Guide Steering Cable (transom end) fully retracted, lubricate transom end of steering cables thru grease fittings (a) with 2-4-C w/Teflon (92-825407A12). Lubricate exposed portion of cable end (b) with 2-4-C w/Teflon.
- Lubricate pivot point (c) of steering link rod and ball joint (d) of link rod with SAE 30 Weight Oil.
- Inspection and lubrication of steering head assembly (rotary or straight rack) should be performed once each year (by your Authorized Dealer) or whenever steering mount and/or steering head are disassembled, or if steering effort has increased. Lubricate with 2-4-C w/Teflon. Ride Guide Steering Cable / Attaching Kit Installation (92876A3).

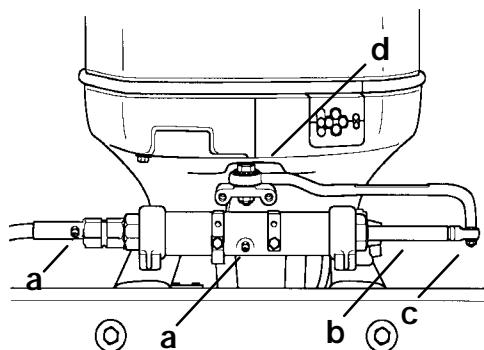

28169



Ride Guide Steering Cable/ Attaching Kit Installation (92876A3)

Dual Cable - Single Outboard

⚠ WARNING

Quicksilver Super Ride-Guide Steering (dual cables) **MUST BE USED** with this attaching kit. Failure to adhere to this requirement could result in steering system failure.

Refer to "Quicksilver Accessories Guide" to determine correct length of steering cables and remote control cables.

IMPORTANT: Steering cables and remote control cables **MUST BE THE CORRECT LENGTH**, sharp bends on too-short cables result in "kinks"; too-long cables require unnecessary bends and/or loops. Both conditions place extra stress on the cables and will reduce the performance of the steering system.

⚠ CAUTION

With this kit installed, the upper (outboard) mounting bolts **MUST BE** installed so that hex head end of bolts is on the inside of boat transom, as illustrated. Failure to install upper mounting bolts, as shown in illustration, could result in interference between steering cable nut and ends of mounting bolts when outboard is tilted up.

⚠ CAUTION

Marine sealer must be used on shanks bolts to make a water-tight installation.

IMPORTANT: DO NOT use an impact driver when tightening transom bolts.

Apply marine sealer to shanks of mounting bolts (not threads) and secure outboard to transom with 4 bolts, flat washers and locknuts, as shown. Be sure that installation is water-tight.

Install upper bolts so that hex head end of bolts is on the inside of boat transom.

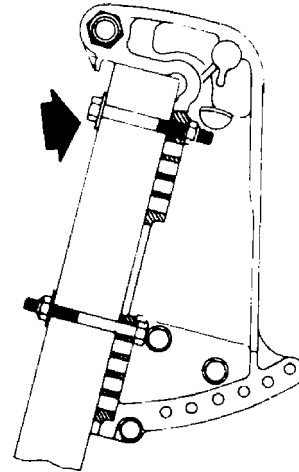

Super Ride-Guide Steering Kit Installation

IMPORTANT: Both gear racks or rotary steering heads **must be installed** so that both steering cables will be routed together on the same side of the boat and will push-and-pull together.

1. Install Super Ride-Guide Steering Kit in accordance with instructions included with Super Ride-Guide Kit.
2. Make sure that both gear racks or rotary steering heads are installed so that both steering cables are routed together down starboard side of boat and will push-and-pull together.

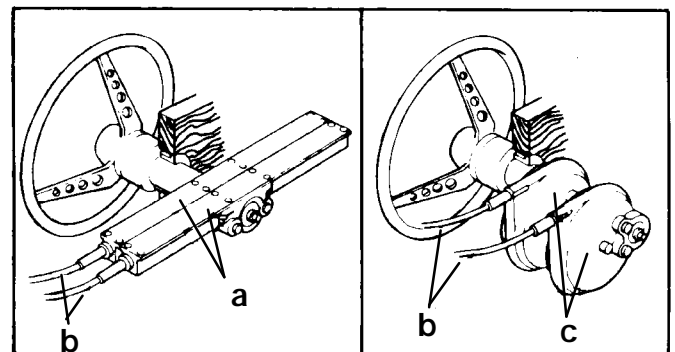

- a - Gear Rack
- b - Steering Cables
- c - Rotary Steering Heads



Steering Cable Mounting Tube Installation

IMPORTANT: Spacers (b) must be installed between outboard swivel bracket and mounting bracket for steering cable mounting tube to provide proper spacing between steering cables.

Secure mounting bracket for steering cable mounting tube on to swivel bracket of outboard.

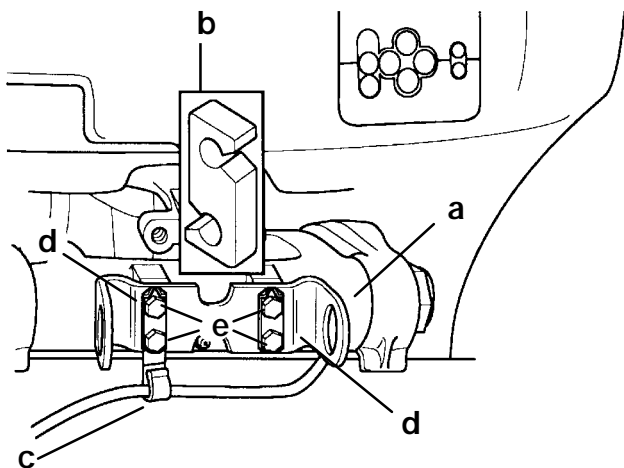

- a - Mounting Bracket for Steering Cable Mounting Tube 28163
- b - Spacer (2)
- c - Locking Retainer (2)
- d - Bolts (4) - 7/8 in. (22mm) Long - Torque to 100 lb. in. (11.3 N·m), then Bend Corner Tabs of Locking Retainers Up and Against Flats on Each Bolt

⚠ WARNING

Locking retainer corner tabs, **MUST BE bent up and against flats on each bolt that secures mounting bracket for steering cable mounting tube to outboard swivel bracket to prevent bolts from turning out.**

Install steering cable mounting tube into mounting bracket with 2 adjusting nuts and 2 locking tab washers. Verify longer threaded end of tube is toward starboard side of boat.

Temporarily adjust tube so that longer threaded end of tube extends out the same distance as the outboard tilt tube. Do not tighten adjustment nuts at this time.

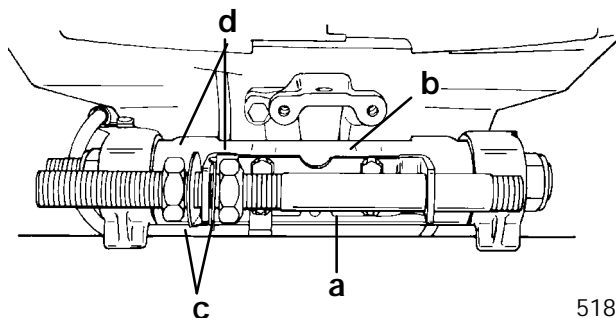

51891

- a - Steering Cable Mounting Tube (End of Tube with Longer Threads Toward Starboard Side of Boat)
- b - Mounting Bracket
- c - Locking Tab Washers (2)
- d - Adjustment Nuts (Flats of Nuts Facing Toward Locking Tab Washer)

Installing Steering Cables

IMPORTANT: Lubricate inside of outboard tilt tube, inside of steering cable mounting tube and rubber O-ring seal (located in outboard tilt tube) with Quicksilver 2-4-C w/Teflon before installing steering cables.

Lubricate inside of outboard tilt tube and inside of steering cable mounting tube with Quicksilver 2-4-C w/Teflon. Verify rubber O-ring seal (a) (located in outboard tilt tube) is lubricated.

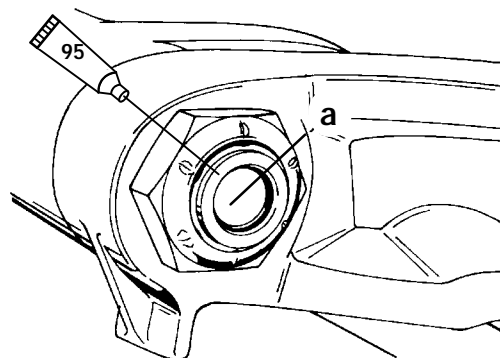

51890

 95 2-4-C With Teflon (92-825407A12)



Insert steering cable ends (a) thru outboard tilt tube (b) and cable mounting tube (c). Thread steering cable attaching nuts (d) on to tubes hand tight.

NOTE: Torque steering cable attaching nuts only after final steering adjustments have been made.

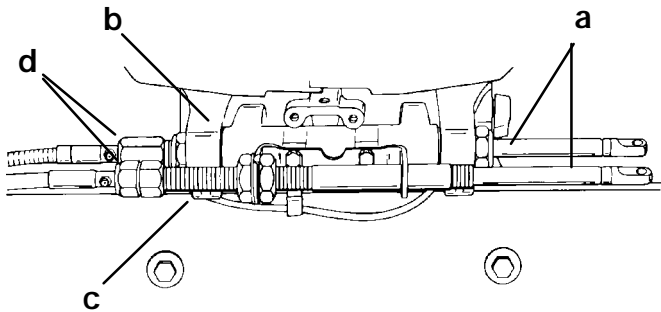

51891

Place a mark (a) on steering cable mounting tube (b) 5/8 in. (16mm) from end of mounting tube. Slide plastic spacer (c), O-ring (d) and cap (e) over steering cable.

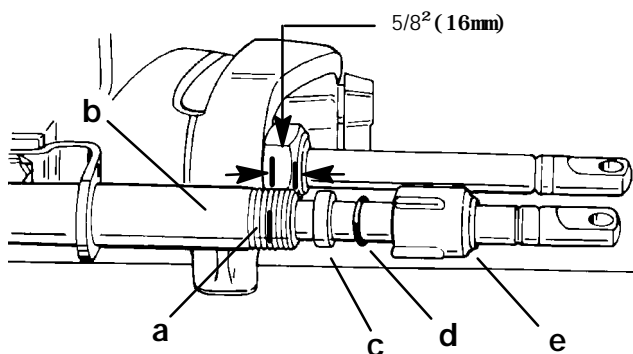

51890

Thread cap (e) onto steering cable mounting tube, up to mark (a).

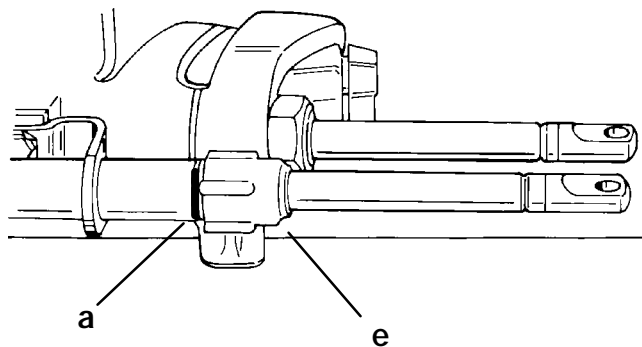

51890

Coupler Installation

⚠ WARNING

Locknuts must be used with bolts to secure steering cables to coupler. Failure to adhere to this requirement could result in steering system failure.

Slide coupler (a) onto steering cable ends and secure each steering cable to coupler with bolt (b) and locknut (c) as shown. Tighten to a torque of 20 lb. ft. (27.1 N·m).

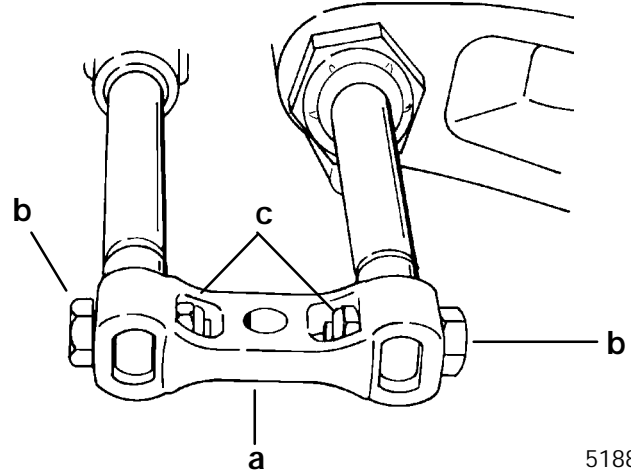

51888

Installing Link Rod

⚠ WARNING

Steering link rod **MUST BE** secured between outboard steering arm and steering coupler, using special washer head bolt (10-14000) and two nylon insert locknuts (11-34863), as shown. Both special washer head bolt and nylon insert locknuts **MUST BE** tightened as specified.

Lubricate hole in steering coupler, with Quicksilver 2-4-C w/Teflon. Assemble steering link rod to steering coupler, using 2 flat washers (one each side of coupler) and nylon insert locknut. Tighten locknut until it seats [DO NOT exceed 120 lb. in. (13.6 N·m) of torque], then back nut off 1/4 turn.



Lubricate ball joint in steering link rod with SAE 30W Motor Oil. Secure link rod to outboard steering arm, using special washer head bolt (10-14000) provided and nylon insert locknut as shown. Torque special bolt to 20 lb. ft. (27.1 N·m), then torque locknut to 20 lb. ft. (27.1 N·m).

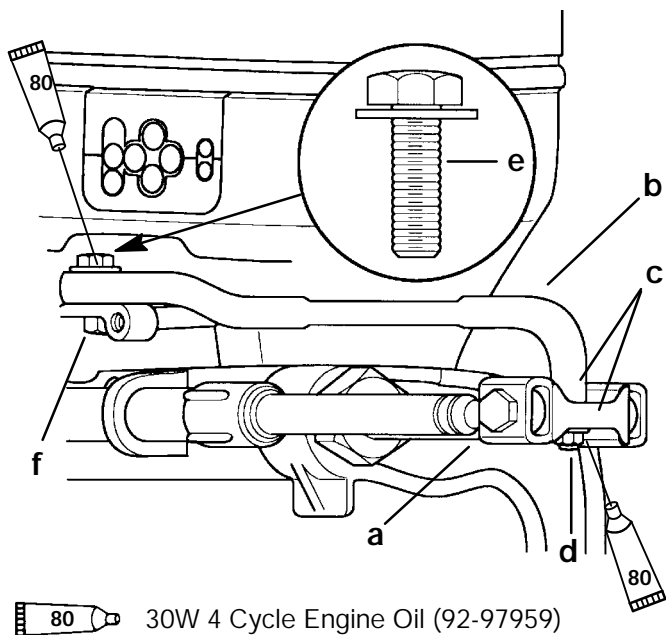

28172

- a - Steering Coupler
- b - Steering Link Rod
- c - Flat Washer (2)
- d - Nylon Insert Locknut - Torque until it seats [DO NOT exceed 120 lb. in. (14.0 N·m) of torque], then back nut off 1/4 turn
- e - Special Washer Head Bolt (10-14000) - Torque to 20 lb. ft. (27.1 N·m)
- f - Nylon Insert Locknut - Torque to 20 lb. ft. (27.1 N·m)

STEERING SYSTEM TENSION ADJUSTMENT

IMPORTANT: After this dual steering cable attachment kit is installed, there must be proper tension in forward mounted steering cable for this attachment kit to operate properly. Not enough tension will cause slack (or play) in steering system. Too much tension will cause steering cables to bind. Perform the following steps to adjust for correct tension.

Loosen adjustment nuts and pull steering cable mounting tube (by hand) away from end of steering cable (to remove slack in steering system). Tighten adjustment nuts against mounting bracket and check system for slack (play.) If steering system is too tight, readjust tube toward end of steering cable or, if too much slack (play) exists in system, readjust tube away from end of steering cable. Tighten nuts against mounting bracket and readjust, if necessary.

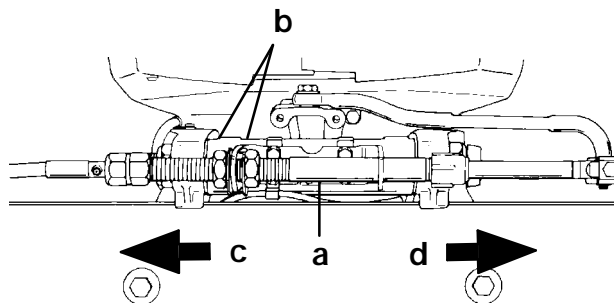

51887

- a - Steering Cable Mounting Tube
- b - Adjustment Nuts
- c - Adjust Tube in This Direction to Remove Slack from Steering System
- d - Adjust Tube in This Direction to Reduce Tension from Steering System

After steering system tension is adjusted correctly, tighten adjustment nuts against mounting bracket, to a torque of 35 lb. ft. (47.4 N·m) and bend a tab lock washer against flat on each adjustment nut.

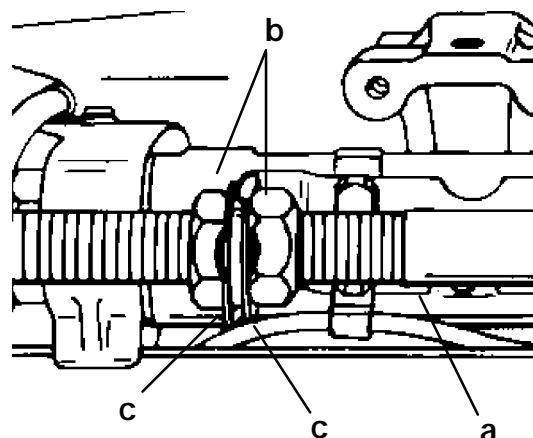

51887

- a - Steering Cable Mounting Tube
- b - Adjustment Nuts; Torque to 35 lb. ft. (47.4 N·m)
- c - Tab Lock Washer (Bend Against Flat on Each Adjustment Nut)



Tighten steering cable attaching nuts of each steering cable to a torque of 35 lb. ft. (47.5 N·m).

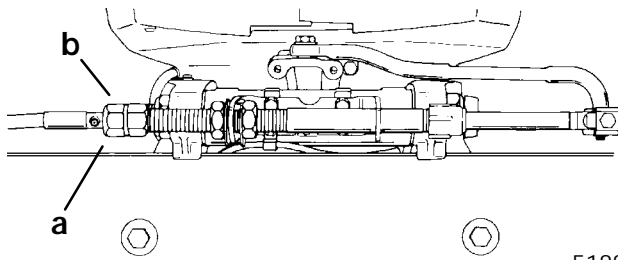

51889

- a - Cable Attaching Nut
- b - "V" Groove

NOTE: Cable attaching nuts with a "V" groove around the outer circumference of the nut are self locking and do not require locking sleeves.

Install rubber bumpers (a) on inside of each locking sleeve (b).

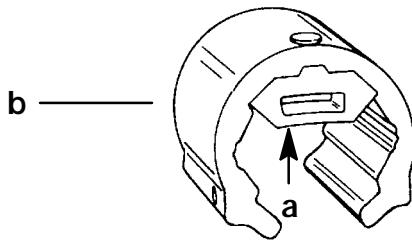

51889

Install locking sleeves over steering cable attaching nuts and secure with cotter pins. Spread ends of cotter pins. Be sure to install cotter pin so that it is located in between attaching nut and grease fitting.

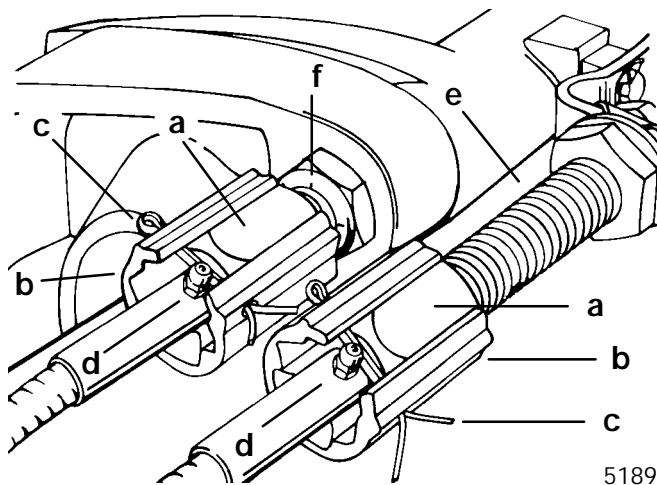

51890

- a - Steering Cable Attaching Nut [Torque to 35 lb. ft. (47.5 N·m)]
- b - Locking Sleeve (If Equipped)
- c - Cotter Pin
- d - Grease Fitting
- e - Steering Cable Mounting Tube
- f - Outboard Tilt Tube

⚠ WARNING

After installation is complete (and before operating outboard(s), check that boat will turn right when steering wheel is turned right and that boat will turn left when steering wheel is turned left. Check steering thru full range (left and right) at all tilt angles to assure interference-free movement.

Maintenance Instructions

Maintenance inspection is owner's responsibility and must be performed at intervals specified, following:

- Normal Service** - Every 50 hrs. of operation or 60 days (whichever comes first)
- *Severe Service** - Every 25 hrs. of operation or 30 days (whichever comes first)

*Operation in a salt water area is considered "Severe Service."

1. Carefully check steering system components for wear. Replace worn parts.
2. Check steering system fasteners to be sure that they are torqued to correct specifications.

NOTE: Ride-Guide Steering Cables are lubricated at the factory and require no additional lubrication at initial installation.

⚠ WARNING

Core of each steering cable (transom end) must be fully retracted into cable housing before lubricating cable. If cable is lubricated while extended, hydraulic lock could occur.



3. With core of Ride-Guide Steering Cable (transom end) fully retracted, lubricate transom end of steering cables thru grease fittings (a) with 2-4-C w/Teflon (92-825407A2).
4. Lubricate ball joint (d) of link rod/steering coupler and pivot point (c) of steering link rod with SAE 30W Motor Oil.
5. Inspection and lubrication of steering head assembly (rotary or straight rack) should be performed once each year (by your Authorized Dealer) or whenever steering mount and/or steering head are disassembled, or if steering effort has increased. Lubricate with 2-4-C w/Teflon.

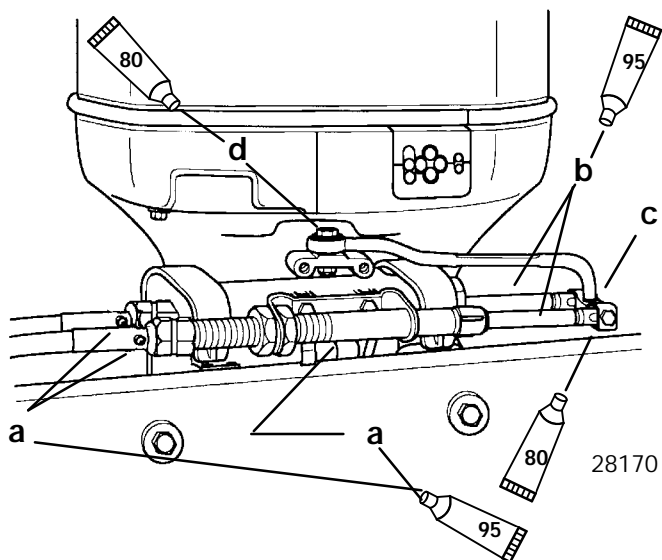

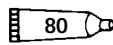
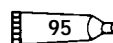
-  30W 4 Cycle Engine Oil (92-97959)
-  2-4-C With Teflon (92-825407A12)

Ride Guide Steering Cable/ Attaching Kit Installation (92876A6)

Dual Cable - Dual Outboard

WARNING

Quicksilver Super Ride-Guide Steering (dual cables) MUST BE USED with this attaching kit. Failure to adhere to this requirement could result in steering system failure.

Refer to "Quicksilver Accessories Guide" to determine correct length of steering cable and remote control cables.

IMPORTANT: Steering cable and remote control cables MUST BE THE CORRECT LENGTH, sharp bends on too-short cables result in "kinks"; too-long cables require unnecessary bends and/or loops. Both conditions place extra stress on the cables.

Installation Requirements

IMPORTANT: The distance from each outboard's centerline to the side of transom opening MUST BE a minimum of 16 in. (40.6cm).

This kit contains all necessary parts to connect both outboards to Ride-Guide Steering Cables for 23-1/2 in. thru 27-1/2 in. (59.7cm thru 69.9cm) outboard centerline spacing. If outboard centerline distance is other than specified, refer to end of this instruction manual for optional extension couplers.

DETERMINE ROUTING OF STEERING CABLES

Use "1" or "2", following, to route steering cables:

1. **Parallel cable routing:** Cables routed together down starboard side of boat. Refer to "Parallel Routed Steering Cables and Attaching Kit Installation," immediately following.
2. **Opposite side cable routing:** One cable routed down starboard side of boat and one cable routed down port side of boat. Refer to "Opposite Side Routed Steering Cables and Attaching Kit Installation," located on page 20 of this instruction manual.



⚠ CAUTION

With this kit installed, the upper (outboard) mounting bolts **MUST BE** installed so that hex head end of bolts is on the inside of boat transom, as illustrated. Failure to install upper mounting bolts, as shown in illustration, could result in interference between outer steering cable locking sleeve and ends of mounting bolts when outboard is tilted up.

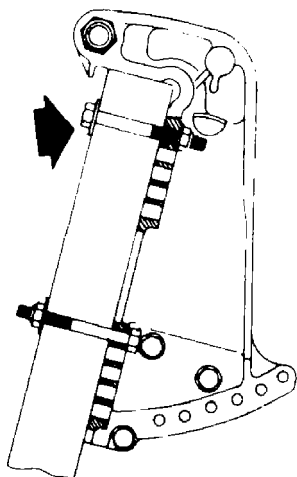

Install upper bolts so that hex head end of bolts is on the inside of boat transom.

Parallel Routed Steering Cables and Attaching Kit Installation

(Both Steering Cables Routed Together Down Starboard Side of Boat)

SUPER RIDE-GUIDE STEERING KIT INSTALLATION

IMPORTANT: Steering cable must be installed into tilt tube of port outboard before outboard is mounted on boat transom.

Both gear racks or rotary steering heads must be installed so that both steering cables will be routed together on the same side of the boat and will push- and-pull together.

1. Install Super Ride-Guide Steering Kit in accordance with instructions included with Super Ride-Guide Kit.

2. Make sure that both gear racks or rotary steering heads are installed so that both steering cables are routed together and will push-and-pull together.

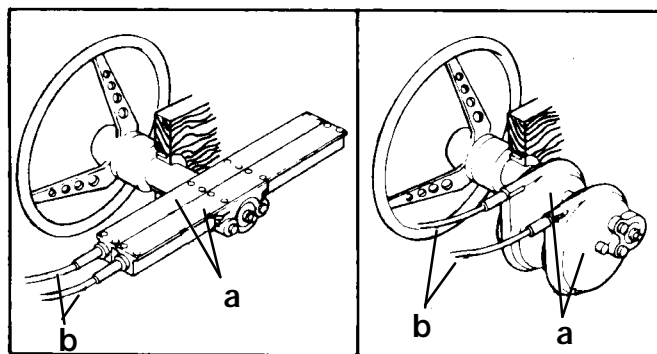

- a - Straight Rack (Left); Rotary Steering (Right)
b - Steering Cables (Install so that Both Cables Will Push and Pull Together)

STEERING CABLE INSTALLATION STARBOARD OUTBOARD

IMPORTANT: Mounting bracket for steering cable mounting tube **MUST BE** secured to outboard swivel bracket, using 5/8 in. (16mm) long bolts supplied with this dual cable - dual outboard attaching kit.

Secure mounting bracket for steering cable mounting tube, onto swivel bracket of starboard outboard.

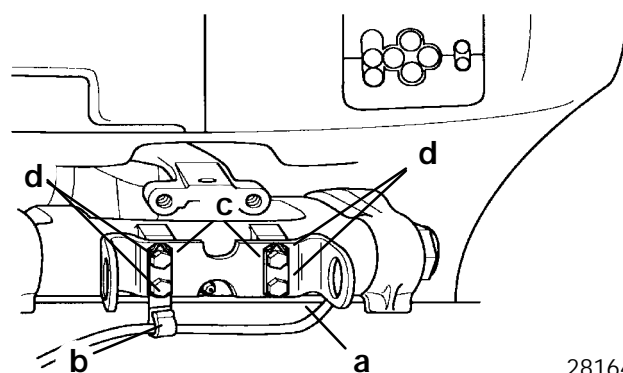

- 28164
a - Mounting Bracket for Steering Cable Mounting Tube
b - "J" Clip - Supplied with Outboard
c - Locking Retainers (2)
d - Bolts (4) - 5/8 in. (16mm) Long - Torque to 100 lb. in. (11.3 N·m), then Bend Corner Tabs of Locking Retainers Up and Against Flats on Each Bolt

⚠ WARNING

Locking retainer corner tabs, **MUST BE** bent up and against flats on each bolt that secures mounting bracket for steering cable mounting tube to outboard swivel bracket, to prevent bolts from turning out.



Install steering cable mounting tube into mounting bracket with 2 adjusting nuts and 2 locking tab washers. Be sure longer threaded end of tube is toward starboard side of boat.

Temporarily adjust tube, so that longer threaded end of tube extends out the same distance as the outboard tilt tube. Do not tighten adjustment nuts at this time.

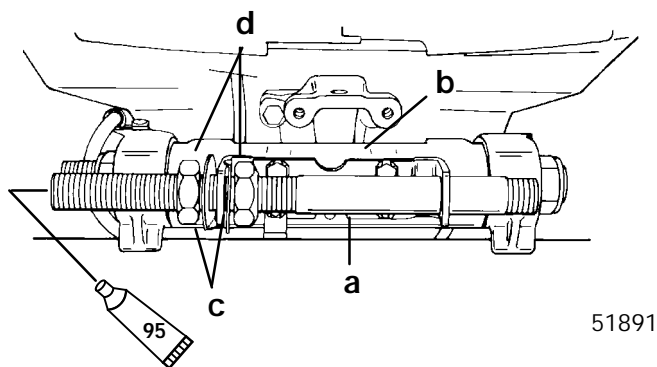

51891

 95 2-4-C With Teflon (92-825407A12)

- a - Steering Cable Mounting Tube (End of Tube with Longer Threads Toward Starboard Side of Boat)
- b - Mounting Bracket
- c - Locking Tab Washers (2)
- d - Adjustment Nuts (Flats of Nuts Facing Toward Locking Tab Washer)

IMPORTANT: Lubricate inside of steering cable mounting tube with 2-4-C w/Teflon before installing steering cable.

Lubricate inside of steering cable mounting tube (starboard outboard) with 2-4-C w/Teflon.

Insert steering cable end (a) thru cable mounting tube (b) and thread steering cable attaching nut (c) onto tube hand tight.

NOTE: Torque steering cable attaching nut only after final steering adjustments have been made.

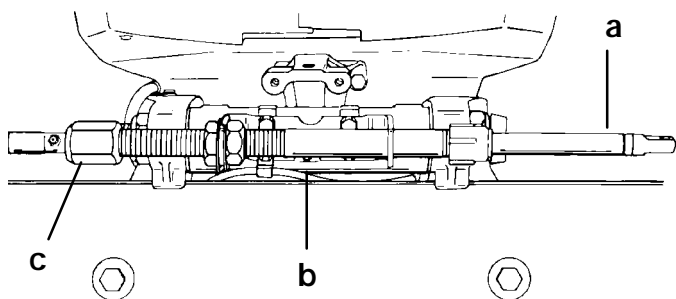

51887

Place a mark (a) on steering cable mounting tube (b) 5/8 in. (16mm) from end of mounting tube. Slide plastic spacer (c), O-ring (d) and cap (e) over steering cable.

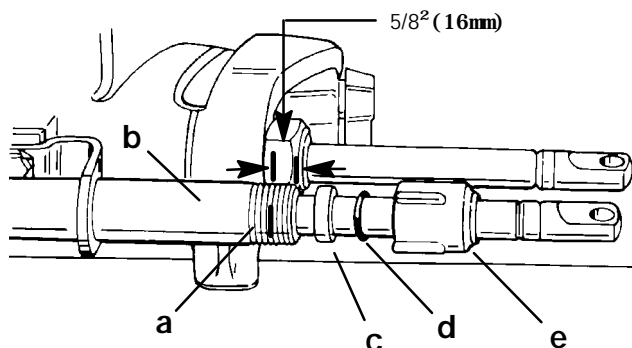

51890

Thread cap (e) onto steering cable mounting tube, up to mark (a).

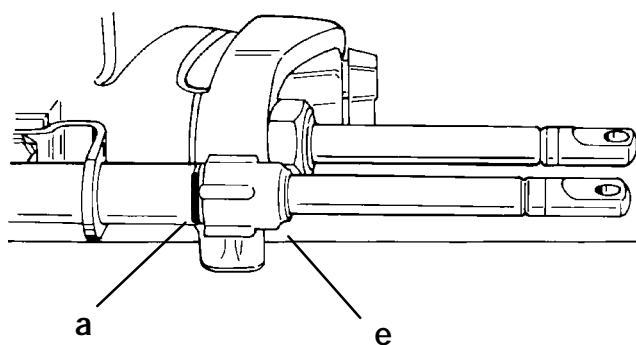

51890



STEERING CABLE INSTALLATION - PORT OUTBOARD

IMPORTANT: Lubricate inside of port outboard's tilt tube and rubber O-ring seal located inside tilt tube with 2-4-C w/Teflon, before installing steering cable.

Lubricate inside of port outboard's tilt tube and rubber O-ring seal (a) with 2-4-C w/Teflon.

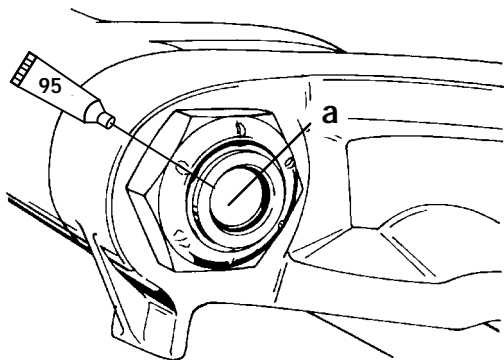

51890

 95 2-4-C With Teflon (92-825407A12)

Insert steering cable end (b) thru tilt tube (c) of port outboard and thread steering cable attaching nut (d) onto tilt tube hand tight.

NOTE: Torque steering cable attaching nuts only after final steering adjustments have been made.

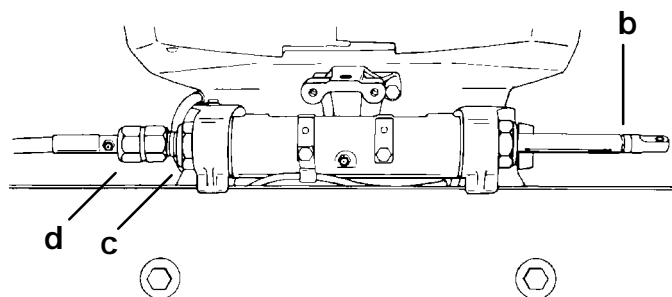

51887



STEERING LINK ROD INSTALLATION

⚠ WARNING

Steering link rods **MUST BE** secured between outboard steering arm and steering cable end, using special washer head bolt (10-14000) and two nylon insert locknuts (11-34863), as shown.

Both special washer head bolt and nylon insert locknuts **MUST BE** tightened as specified.

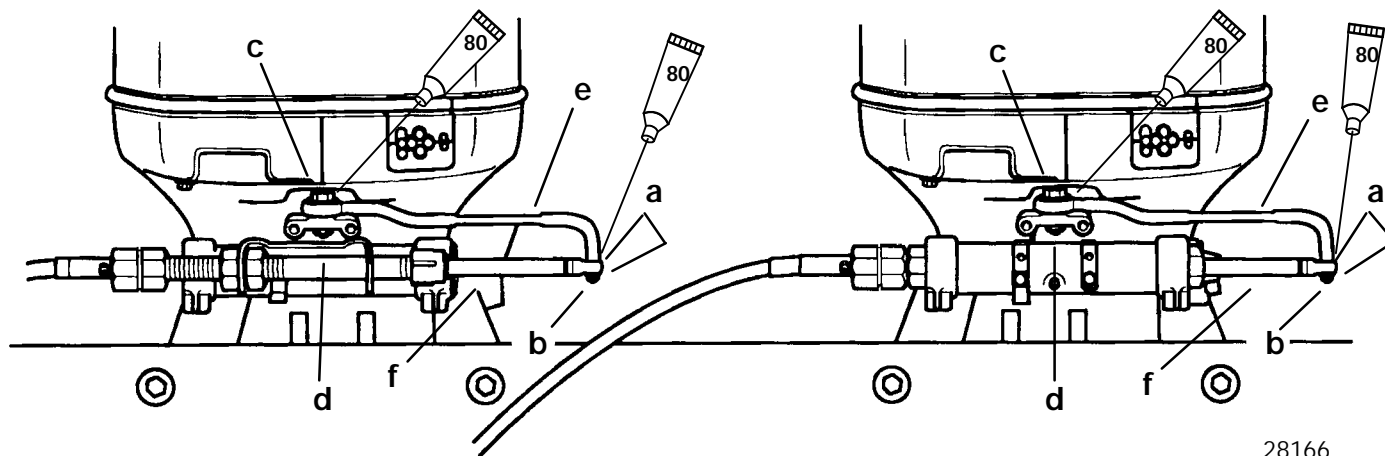
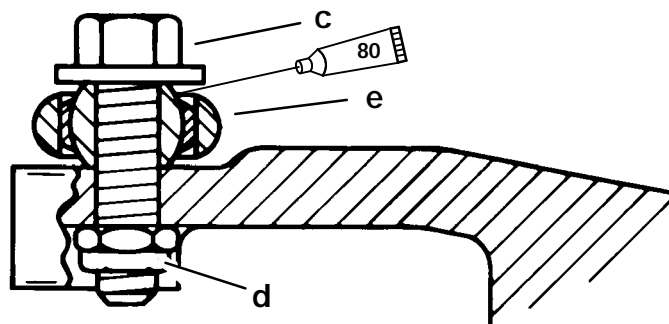

28166

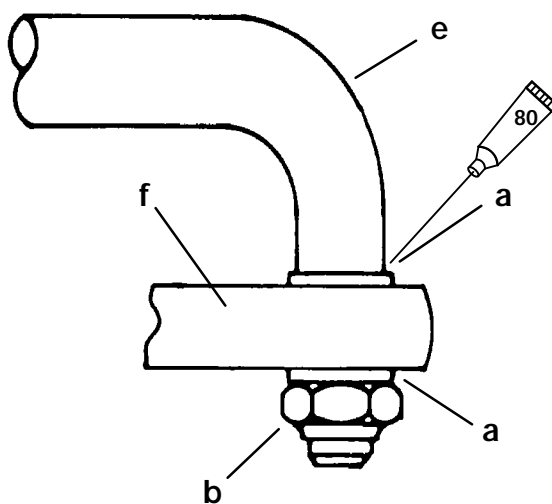

 30W 4 Cycle Engine Oil (92-97959)

- a - Flat Washer (2 Each Link Rod)
- b - Nylon Insert Locknut - Torque Until it Seats [DO NOT Exceed 120 lb. in. (13.6 N·m) of Torque], Then Back Off 1/4 Turn
- c - Special Washer Head Bolt (10-14000) - Torque to 20 lb. ft. (27.1 N·m)
- d - Nylon Insert Locknut - Torque to 20 lb. ft. (27.1 N·m)
- e - Steering Link Rod
- f - Steering Cable End

Lubricate holes in ends of steering cables with SAE 30W Motor Oil. Assemble steering link rods to steering cable ends of each outboard, using flat washers and nylon insert locknuts. Tighten locknuts until they seat [DO NOT exceed 120 lb. in. (13.6 N·m) of torque], then back nut off 1/4 turn.

Lubricate ball joints in steering link rods with SAE 30W Motor Oil. Secure link rods to outboard steering arms, using special washer head bolts (10-14000) provided and nylon insert locknuts as shown. Torque special bolts to 20 lb. ft. (27.1 N·m) then torque locknuts to 20 lb. ft. (27.1 N·m).



STEERING ARM EXTENSION BRACKET INSTALLATION

Secure a steering arm extension bracket to each outboard's steering arm.

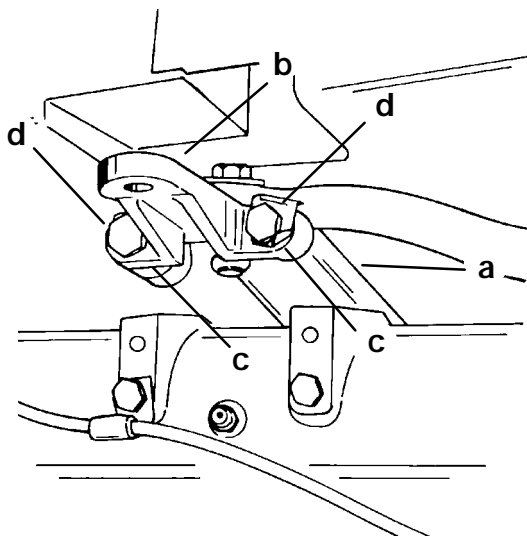

51889

- a - Steering Arm (Port Outboard Shown)
- b - Extension Bracket
- c - Locking Retainer (2 Each Bracket)
- d - Bolts (2 Each Bracket) 1-1/4 in. (31.8mm) Long - Torque to 280 lb. in. (31.6 N·m), Then Bend Corner Tabs of Locking Retainers Up Against Flats on Each Bolt

⚠ WARNING

Locking retainer corner tabs MUST BE bent up and against flats on each bolt that secures extension bracket to outboard steering arm to prevent bolts from turning out.

STEERING COUPLER ASSEMBLY AND INSTALLATION

Position outboards so that they are facing straight forward. (Distance between threaded hole centers of steering arm extensions **MUST BE** equal to distance between propeller shaft centerlines.)

Lubricate inside of rubber sleeves with 2-4-C w/Teflon and slide sleeves on steering coupler.

Work rubber bushings onto threaded ends of steering eyes.

Thread jam nut on starboard steering eye.

Thread steering eyes equally into coupler, so that distance between hole centers of steering eye ball joints is equal to distance between threaded hole centers of steering arm extensions. Exposed threads of steering eyes **MUST BE** of equal length and threads **MUST NOT** extend out from coupler more than 2-3/4 in. (69.9mm).

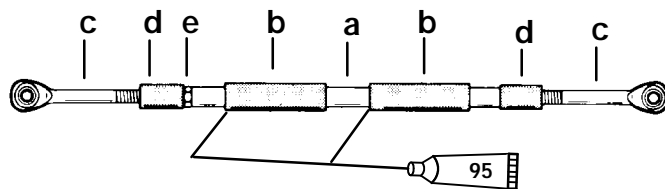

50061

95 2-4-C With Teflon (92-825407A12)

- a - Coupler
- b - Rubber Sleeve
- c - Steering Eye
- d - Rubber Bushing
- e - Jam Nut

⚠ WARNING

Both steering eyes must be threaded into coupler 3/4 in. (19mm) minimum. Thread length of steering eye is 3-1/2 in. (88.9mm), so exposed thread must not extend out of coupler more than 2-3/4 in. (69.9mm). Failure to adhere to this requirement could result in steering system failure.



Lubricate ball joint in steering eyes, with SAE 30W Motor Oil.

Assemble steering coupler between outboard steering arm extension brackets, using special washer head bolts (10-14000) provided and nylon insert locknuts as shown.

IMPORTANT: With assembled steering coupler installed and before tightening special washer head bolts/locknuts, check outboard alignment. Distance between centers of special washer head bolts **MUST BE** equal to distance between propeller shaft center lines, for proper steering. It adjustment is necessary, temporarily remove special washer head bolt/locknut from one steering eye and turn eye in or out to correct alignment.

Torque special washer head bolts to 20 lb. ft. (27.1 N·m), then torque locknuts to 20 lb. ft. (27.1 N·m).

⚠ WARNING

Both steering eyes MUST BE threaded into coupler 3/4 in. (19mm) minimum, and jam nut must be tightened against coupler to prevent coupler from turning. Torque "jam" nut to 20 lb. ft. (27.1 N·m).

Tighten "jam" nut against coupler. Torque "jam" nut to 20 lb. ft. (27.1 N·m).

Spray Quicksilver Corrosion Guard on exposed threads of steering eyes and position rubber bushings and rubber sleeves to cover exposed threads of steering eyes.

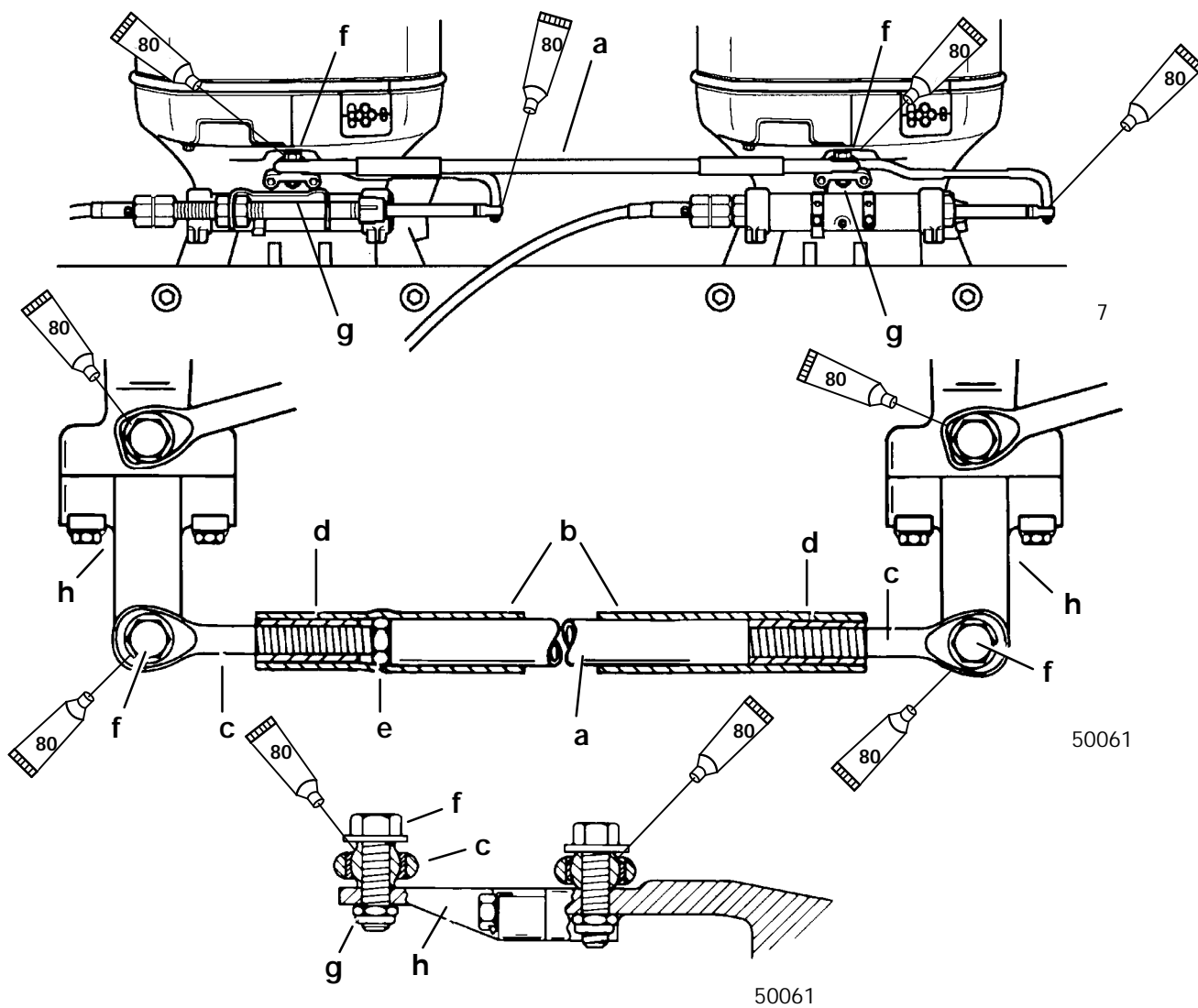

30W 4 Cycle Engine Oil (92-97959)

- a - Coupler
- b - Rubber Sleeve
- c - Steering Eye
- d - Rubber Bushing
- e - Jam Nut - Torque (Against Coupler) to 20 lb. ft. (27.1 N·m)
- f - Special Washer Head Bolt (10-14000) - Torque to 20 lb.ft. (27.1 N·m)
- g - Nylon Insert Locknut - Torque to 20 lb. ft. (27.1 N·m)
- h - Steering Arm Extension Bracket



STEERING SYSTEM TENSION ADJUSTMENT (PARALLEL ROUTED STEERING CABLES)

IMPORTANT: For proper operation of this dual cable - dual outboard steering installation, there **MUST BE** proper tension in the steering system. **NOT ENOUGH** tension will cause slack (play) in steering system. **TOO MUCH** tension will cause steering cables to bind. Perform the following steps to correctly adjust tension.

Loosen adjustment nuts and pull steering cable mounting tube (by hand) away from end of steering cable (to remove slack in steering system). Tighten adjustment nuts against mounting bracket and check system for slack (play). If steering system is too tight, readjust tube toward end of steering cable or, if too much slack (play) exists in system, readjust tube away from end of steering cable. Tighten nuts against mounting bracket and readjust, if necessary.

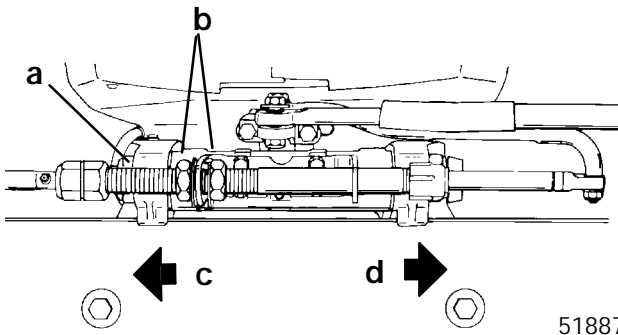

- a - Steering Cable Mounting Tube
- b - Adjustment Nuts
- c - Adjust Tube in This Direction to Remove Slack from Steering System
- d - Adjust Tube in This Direction to Reduce Tension from Steering System

After steering system tension is adjusted correctly, tighten adjustment nuts against mounting bracket, to a torque of 35 lb. ft. (47.5 N·m) and bend a tab lock washer against a flat on each nut.

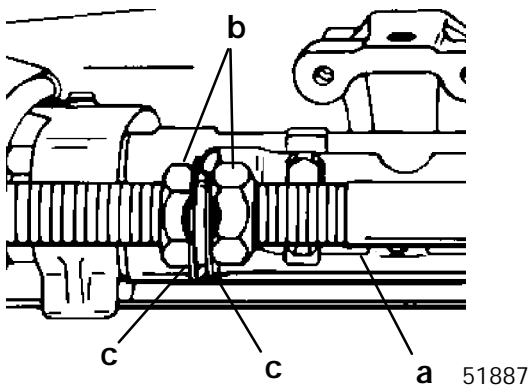

- a - Steering Cable Mounting Tube
- b - Adjustment Nuts Torque to 35 lb. ft. (47.5 N·m)
- c - Tab Lock Washer (Bend Against Flat on Each Adjustment Nut)

Tighten steering cable attaching nuts of each steering cable to a torque of 35 lb. ft. (47.5 N·m).

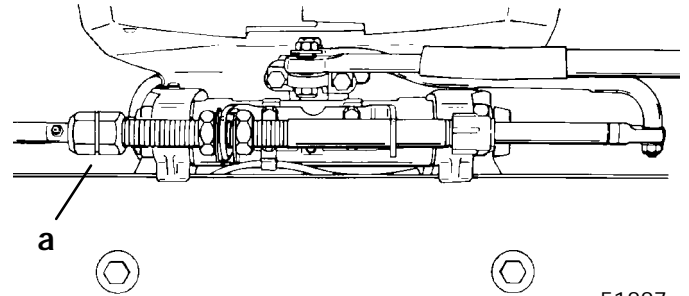

- a - Cable Attaching Nut

⚠ WARNING

After installation is complete [and before operating outboard(s)], check that boat will turn right when steering wheel is turned right and that boat will turn left when steering wheel is turned left. Check steering thru full range (left and right) at all tilt angles to assure interference-free movement.

Adjust trim tabs of both outboards, as outlined in "Trim Tab Adjustment", following.



Opposite Side Routed Steering Cables and Attaching Kit Installation

(One Cable Routed down Starboard Side of Boat and One Cable Routed down Port Side of Boat)

SUPER RIDE-GUIDE STEERING KIT INSTALLATION

IMPORTANT: Steering cable must be installed into tilt tube of port outboard before outboard is mounted on boat transom.

Install Super Ride-Guide Steering Kit in accordance with instructions included with Super Ride-Guide Kit.

STEERING CABLE INSTALLATION - STARBOARD OUTBOARD

IMPORTANT: Mounting bracket for steering cable mounting tube **MUST BE** secured to outboard swivel bracket, using 5/8 in. (16mm) long bolts supplied with this dual cable - dual outboard attaching kit.

Secure mounting bracket for steering cable mounting tube, onto swivel bracket of starboard outboard.

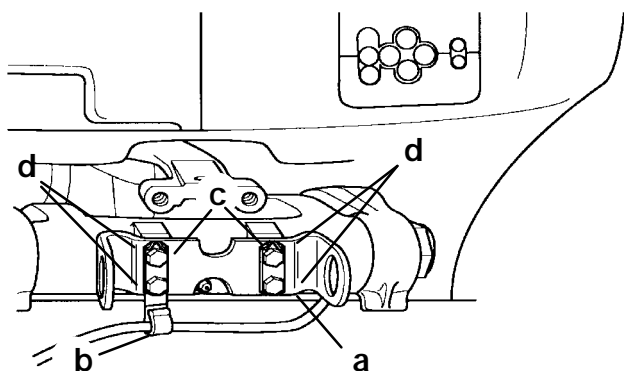

28164

- a - Mounting Bracket for Steering Cable Mounting Tube
- b - "J" Clip - Supplied with Outboard
- c - Locking Retainers (2)
- d - Bolts (4) - 5/8 in. (16mm) Long - Torque to 100 lb. in. (11.3 N·m), Then Bend Corner Tabs of Locking Retainers Up and Against Flats on Each Bolt

⚠ WARNING

Locking retainer corner tabs **MUST BE** bent up and against flats on each bolt that secures mounting bracket for steering cable mounting tube, to prevent bolts from turning out.

Install Steering Cable mounting tube into mounting bracket with 2 adjusting nuts and 2 locking tab washers. Verify longer threaded end of tube is toward center of boat transom.

Temporarily adjust tube, so that longer threaded end of tube extends out the same distance as the outboard tilt tube. Do not tighten adjustment nuts at this time.

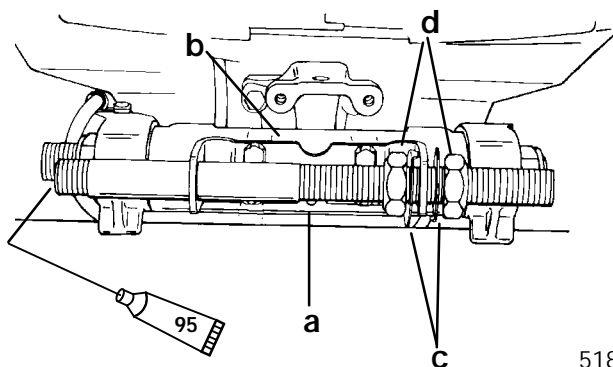

51891

 2-4-C With Teflon (92-825407A12)

- a - Steering Cable Mounting Tube (End of Tube with Longer Threads Toward Center of Boat Transom)
- b - Mounting Bracket
- c - Locking Tab Washers (2)
- d - Adjustment Nuts (Flats of Nuts Facing Toward Locking Tab Washer)

IMPORTANT: Lubricate inside of steering mounting tube with 2-4-C w/Teflon (92-825407A12) before installing steering cable.

Lubricate inside of steering cable mounting tube (starboard outboard) with 2-4-C w/Teflon.

Insert steering cable end (a) (steering cable routed down port side of boat) thru cable mounting tube (b) and thread steering cable attaching nut (c) onto tube hand tight.

NOTE: Torque steering cable attaching nut only after final steering adjustments have been made.

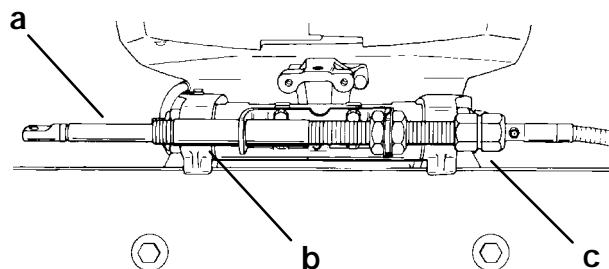

51887



Place a mark (a) on steering cable mounting tube (b) 5/8 in (16mm) from end of mounting tube. Slide plastic spacer (c), O-ring (d) and cap (e) over steering cable.

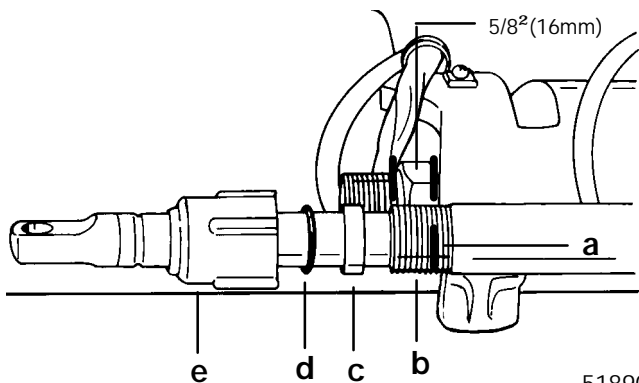

51890
Thread cap (e) onto steering cable mounting tube, up to mark (a).

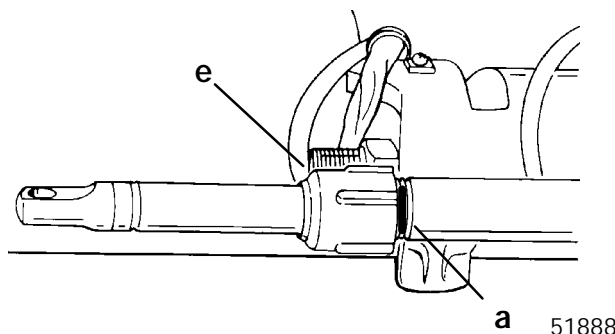

STEERING CABLE INSTALLATION - PORT OUTBOARD

IMPORTANT: Lubricate inside of port outboard's tilt tube and rubber O-ring seal located inside tilt tube with 2-4-C w/Teflon, before installing steering cable.

Lubricate inside of port outboard's tilt tube and rubber O-ring seal (a) with 2-4-C w/Teflon.

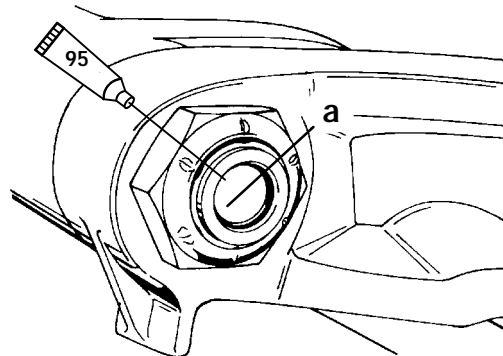

51890

 95 2-4-C With Teflon (92-825407A12)

Insert steering cable end (b) (steering cable routed down starboard side of boat) thru tilt tube (c) of port outboard and thread steering cable attaching nut (d) onto tilt tube hand tight.

NOTE: Torque steering cable attaching nut only after final steering adjustments have been made.

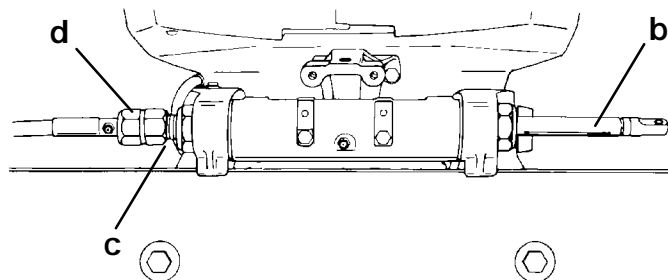

51887



STEERING LINK ROD INSTALLATION

⚠ WARNING

Steering link rods **MUST BE** secured between outboard steering arm and steering cable end, using special washer head bolt (10-14000) and two nylon insert locknuts (11-34863), as shown. Both special washer head bolt and nylon insert locknuts **MUST BE** tightened as specified.

Lubricate holes in ends of steering cables with SAE 30W Motor Oil. Assemble steering link rods to steering cable ends of each outboard, using flat washers and nylon insert locknuts. Tighten locknuts until they seat [DO NOT exceed 120 lb. in. (13.6 N·m) of torque], then back nut off 1/4 turn.

Lubricate ball joints in steering link rods with SAE 30W Motor Oil. Secure link rods to outboard steering arms, using special washer head bolts (10-14000) provided and nylon insert locknuts as shown. Torque special bolts to 20 lb. ft. (27.1 N·m) then torque locknuts to 20 lb. ft. (27.1 N·m).

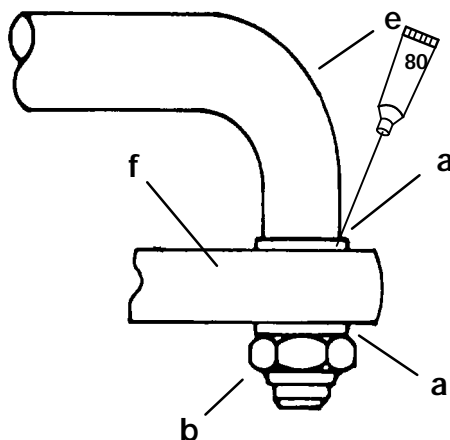
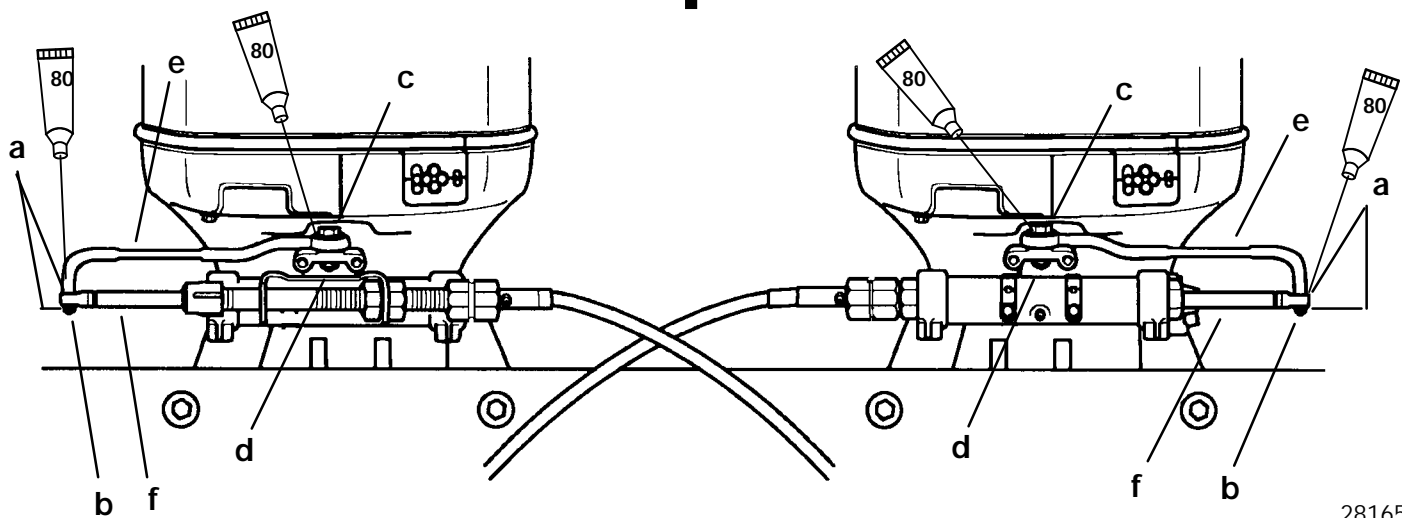
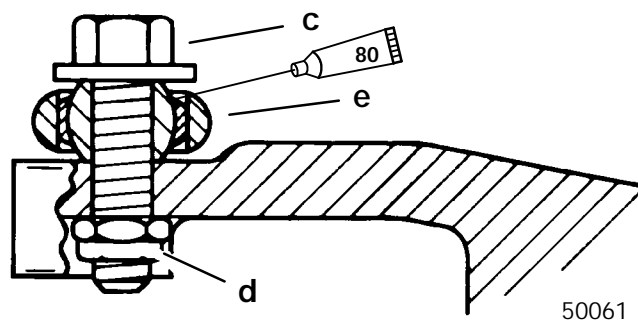

- a - Flat Washer (2 Each Link Rod)
- b - Nylon Insert Locknut - Torque Until it Seats [DO NOT Exceed 120 lb. in. (13.6 N·m) of Torque], Then Back Off 1/4 Turn
- c - Special Washer Head Bolt (10-14000) - Torque to 20 lb.ft. (27.1 N·m)
- d - Nylon Insert Locknut - Torque to 20 lb. ft. (27.1 N·m)
- e - Steering Link Rod
- f - Steering Cable End



STEERING ARM EXTENSION BRACKET INSTALLATION

Secure a steering arm extension bracket to each outboard's steering arm.

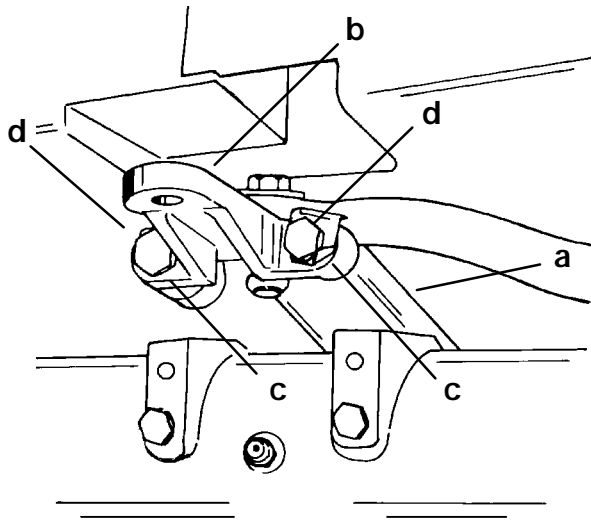

51889

- a - Steering Arm (Port Outboard Shown)
- b - Extension Bracket
- c - Locking Retainer (2 Each Bracket)
- d - Bolts (2 Each Bracket) 1-1/4 in. (31.8mm) Long - Torque to 280 lb. in. (31.6 N-m), Then Bend Corner Tabs of Locking Retainers Up Against Flats on Each Bolt

⚠ WARNING

Locking retainer corner tabs, **MUST BE bent up and against flats on each bolt that secures extension bracket to outboard steering arm, to prevent bolts from turning out.**

STEERING COUPLER ASSEMBLY AND INSTALLATION

Position outboards so that they are facing straight forward. (Distance between threaded hole centers of steering arm extensions **MUST BE** equal to distance between propeller shaft centerlines.)

Lubricate inside of rubber sleeves with 2-4-C w/Teflon and slide sleeves on steering coupler.

Work rubber bushings onto threaded ends of steering eyes.

Thread jam nut on starboard steering eye.

Thread steering eyes equally into coupler, so that distance between hole centers of steering eye ball joints is equal to distance between threaded hole centers of steering arm extensions. Exposed threads of steering eyes **MUST BE** of equal length and threads **MUST NOT** extend out from coupler more than 2-3/4 in. (69.9mm).

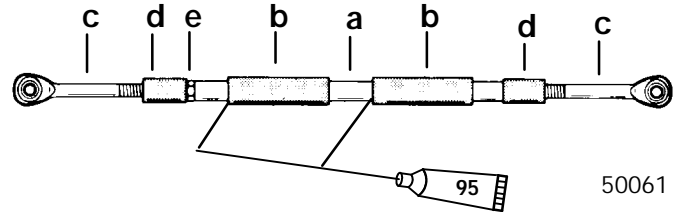

50061

95 2-4-C With Teflon (92-825407A12)

- a - Coupler
- b - Rubber Sleeve
- c - Steering Eye
- d - Rubber Bushing
- e - Jam Nut

⚠ WARNING

Both steering eyes must be threaded into coupler 3/4 in. (19mm) minimum. Thread length of steering eye is 3-1/2 in. (88.9mm), so exposed thread must not extend out of coupler more than 2-3/4 in. (69.9mm). Failure to adhere to this requirement could result in steering system failure.



Lubricate ball joint in steering eyes with SAE 30W Motor Oil.

Assemble steering coupler between outboard steering arm extension brackets, using special washer head bolts (10-14000) provided and nylon insert locknuts, as shown.

IMPORTANT: With assembled steering coupler installed and before tightening special washer head bolts/locknuts, check outboard alignment. Distance between centers of special washer head bolts **MUST BE** equal to distance between propeller shaft center lines, for proper steering. If adjustment is necessary, temporarily remove special washer head bolt/locknut from one steering eye and turn eye in or out to correct alignment.

Torque special washer head bolts to 20 lb. ft. (27.1 N·m), then torque locknuts to 20 lb. ft. (27.1 N·m).

⚠ WARNING

Both steering eyes MUST BE threaded into coupler 3/4 in. (19mm) minimum, and jam nut must be tightened against coupler to prevent coupler from turning. Torque "jam" nut to 20 lb. ft. (27.1 N·m).

Tighten "jam" nut against coupler. Torque "jam" nut to 20 lb. ft. (27.1 N·m).

Spray Quicksilver Corrosion Guard on exposed threads of steering eyes and position rubber bushings and rubber sleeves to cover exposed threads of steering eyes.

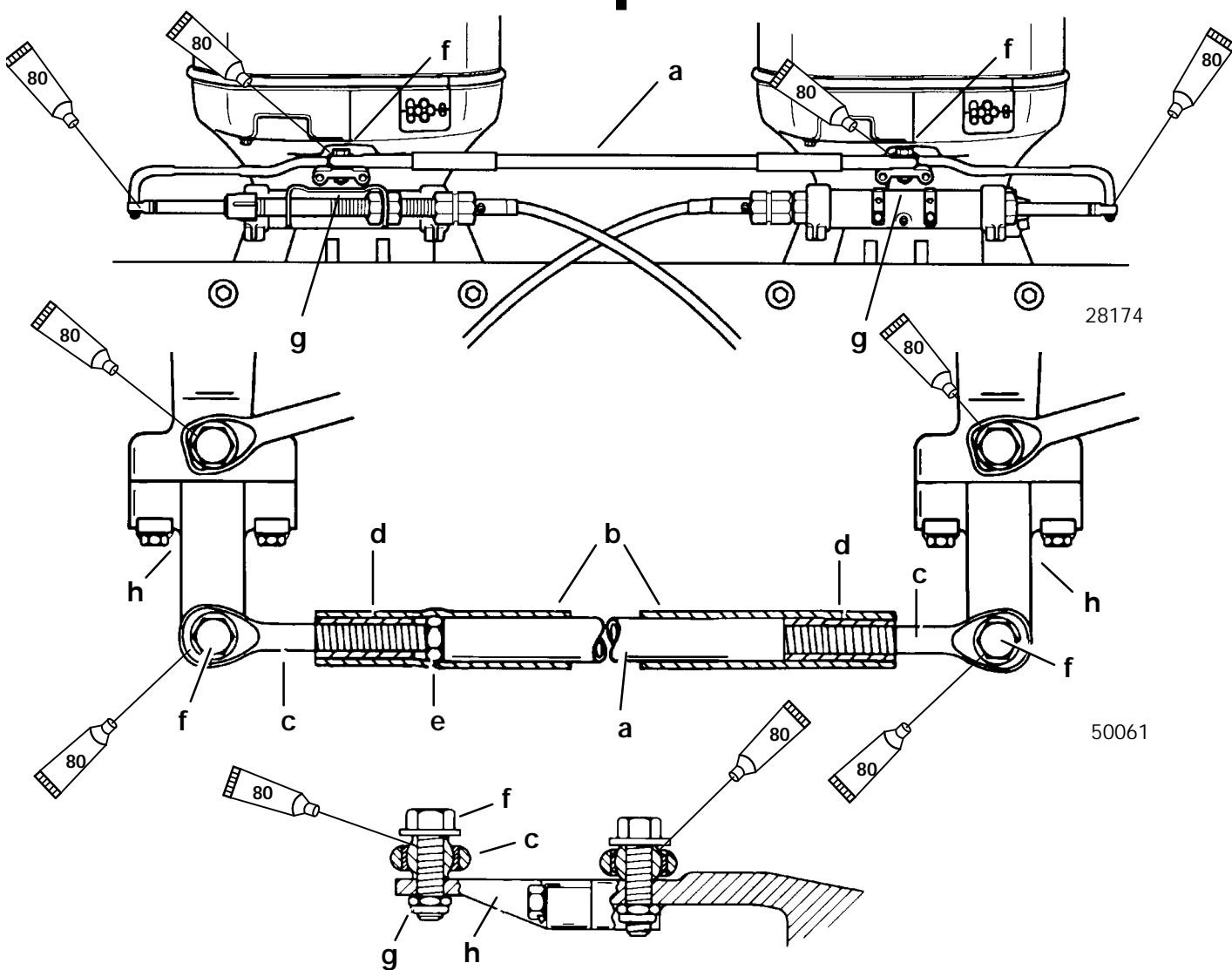

80 30W 4 Cycle Engine Oil (92-97959)

- a - Coupler
- b - Rubber Sleeve
- c - Steering Eye
- d - Rubber Bushing
- e - Jam Nut - Torque (Against Coupler) to 20 lb. ft. (27.1 N·m)

- f - Special Washer Head Bolt (10-14000) - Torque to 20 lb.ft. (27.1 N·m)
- g - Nylon Insert Locknut - Torque to 20 lb. ft. (27.1 N·m)
- h - Steering Arm Extension Bracket



STEERING SYSTEM TENSION ADJUSTMENT (PARALLEL ROUTED STEERING CABLES)

IMPORTANT: For proper operation of this dual cable - dual outboard steering installation, there **MUST BE** proper tension in the steering system. **NOT ENOUGH** tension will cause slack (play) in steering system. **TOO MUCH** tension will cause steering cables to bind. Perform the following steps to correctly adjust tension.

Loosen adjustment nuts and pull steering cable mounting tube (by hand) away from end of steering cable (to remove slack in steering system.) Tighten adjustment nuts against mounting bracket and check system for slack (play.) If steering system is too tight, readjust tube toward end of steering cable or, if too much slack (play) exists in system, readjust tube away from end of steering cable. Tighten nuts against mounting bracket and readjust, if necessary.

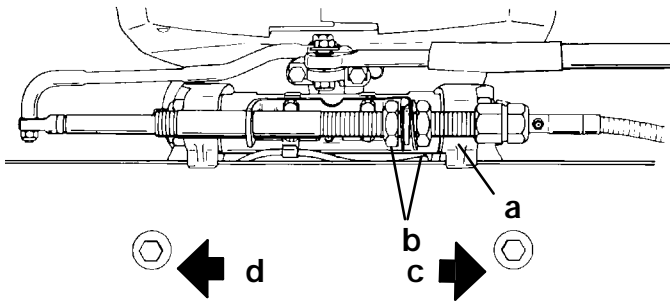

- 51887
- a - Steering Cable Mounting Tube
 - b - Adjustment Nuts
 - c - Adjust Tube in This Direction to Remove Slack from Steering System
 - d - Adjust Tube in This Direction to Reduce Tension from Steering System

After steering system tension is adjusted correctly, tighten adjustment nuts against mounting bracket to a torque of 35 lb. ft. (47.5 N·m) and bend a tab lock washer against a flat on each nut.

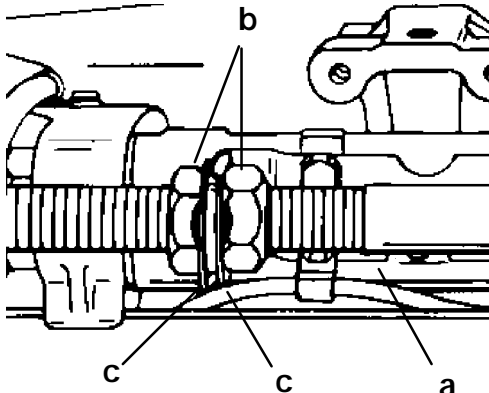

- 51887
- a - Steering Cable Mounting Tube
 - b - Adjustment Nuts; Torque to 35 lb. ft. (47.5 N·m)
 - c - Tab Lock Washer (Bend Against Flat on Each Adjustment Nut)

Tighten steering cable attaching nuts of each steering cable to a torque of 35 lb. ft. (47.5 N·m).

NOTE: Cable attaching nuts with a "V" groove around outer circumference are self locking and do not require locking sleeves.

Install rubber bumpers (a) on inside of each locking sleeve (b).

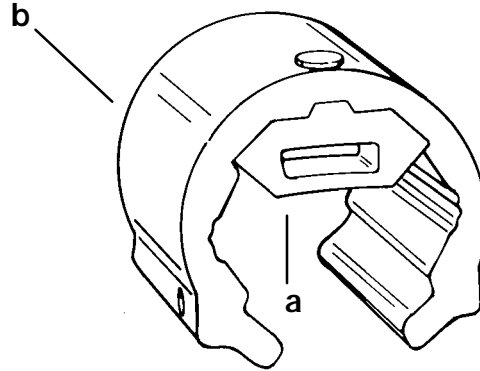

51889

Install locking sleeves over steering cable attaching nuts and secure with cotter pins. Spread ends of cotter pins. Be sure to install cotter pin so that it is located in between attaching nut and grease fitting.

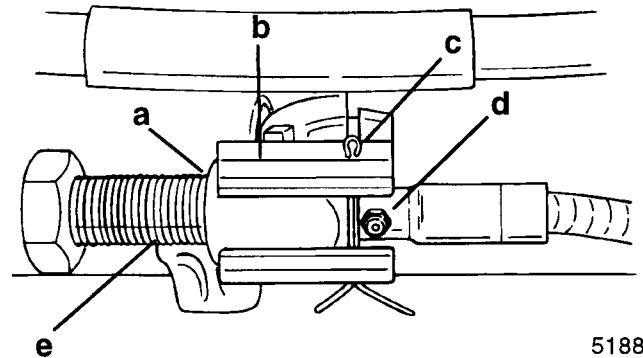

51889

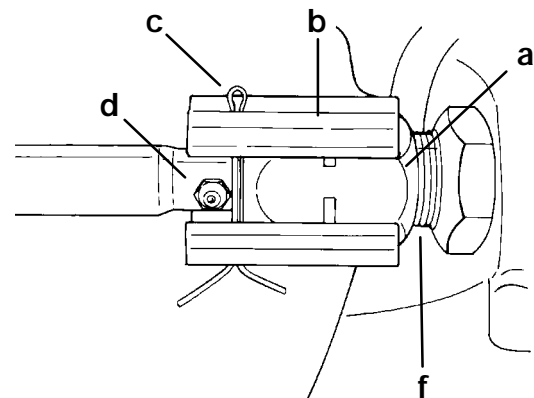

51888

- a - Steering Cable Attaching Nut [Torque to 35 lb. ft. (47.5 N·m)]
- b - Locking Sleeve (If Equipped)
- c - Cotter Pin
- d - Grease Fitting
- e - Steering Cable Mounting Tube (Starboard Outboard)
- f - Outboard Tilt Tube (Port Outboard)



⚠ WARNING

After installation is complete [and before operating outboard(s)], check that boat will turn right when steering wheel is turned right and that boat will turn left when steering wheel is turned left. Check steering thru full range (left and right) at all tilt angles to assure interference-free movement.

Adjust trim tabs of both outboards, as outlined in "Trim Tab Adjustment," following.

Trim Tab Adjustment

DUAL OUTBOARD - COUNTER ROTATION INSTALLATION

1. Shift outboard into neutral and make sure ignition key is at "OFF" position.
2. Remove plastic cap from rear of drive shaft housing and loosen bolt and trim tab.
3. Position trim tabs of both outboards straight to rear of outboard, so that tabs are aligned with gear housing center line.
4. Tighten both trim tab bolts securely and replace plastic caps. No further adjustment will be required.

DUAL OUTBOARD - NON COUNTER ROTATION INSTALLATION

1. Check trim tab position as follows:

IMPORTANT: Initial trim tab setting for both outboards should be straight to rear of outboard, so that tabs are aligned with gear housing center line. Refer to "If necessary, adjust trim tab as follows," following.

- a. Operate boat at normal cruise throttle setting and adjust trim to optimum setting.
 - b. If boat pulls to the right (starboard), trailing edge of trim tab must be moved to the right (when viewing outboard from behind). If boat pulls to the left (port), trailing edge of trim tab must be moved to the left.
2. If necessary, adjust trim tab as follows:
 - a. Shift outboard into NEUTRAL and make sure ignition key is at "OFF" position.
 - b. Remove plastic cap from rear of drive shaft housing and loosen bolt and trim tab.

IMPORTANT: Trim tabs MUST BE set in the same position on both outboards.

- c. If boat pulls to the right, adjust trailing edges of both trim tabs to the right. If boat pulls to the left, adjust trailing edges of both trim tabs to the left.
- d. Tighten both trim tab bolts securely and replace plastic caps.
- e. Operate boat per "Check trim tab position as follows," preceding, to check trim tab setting. Readjust trim tabs, if necessary.

Ride Guide Steering Attachment Extension Couplers

Outboard Center Line Distance	Required Coupler(s) Between Steering Eyes
22-1/2 in. thru 24-1/2 in. (57.2cm thru 62.2cm)	12 in. (30.5cm) Coupler
23-1/2 in. thru 27-1/2 in. (59.7cm thru 69.9cm)	15 in. (38.1cm) Coupler (Supplied with this kit)
26-1/2 in. thru 30-1/2 in. (67.3cm thru 75.5cm)	18 in. (45.7cm) Coupler
30 in. thru 34 in. (76.3cm thru 86.4cm)	9 in. (22.9cm) Coupler and 12 in. (30.5cm) Coupler (Connected together with coupler link rod)
33 in. thru 37 in.	12 in. (30.5cm) Coupler and 12 in. (30.5cm) Coupler (Connected together with coupler link rod)

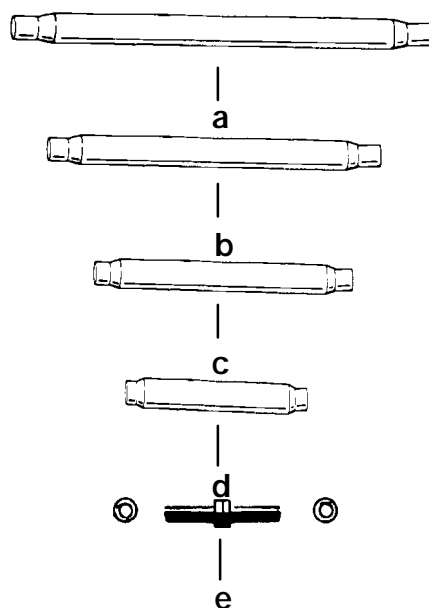

- a - 18 in. (45.7cm) Coupler (97932-3)
- b - 15 in. (38.1cm) Coupler (97932-2)
- c - 12 in. (30.5cm) Coupler (97932-1)
- d - 9 in. (22.9cm) Coupler (97932-4)
- e - Coupler Link Rod (98181A1)



⚠ WARNING

When 2 couplers are connected together with coupler link rod, a lock washer must be used on each side of coupler link rod, and link rod must be torqued to 20 lb. ft. (27.1 N·m) into end of each coupler.

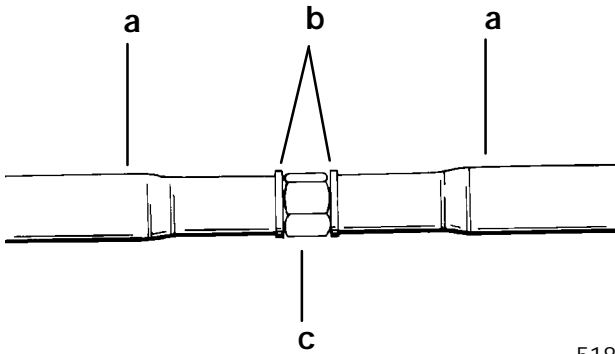

51890

- a - Couplers Connected Together
- b - Lock washers
- c - Coupler Link Rod [Torque to 20 lb. ft. (27.1 N·m) into End of Each Coupler]

Maintenance Instructions

Maintenance inspection is owner's responsibility and must be performed at intervals specified, following:

Normal Service - Every 50 hrs. of operation or 60 days (whichever comes first)

***Severe Service** - Every 25 hrs. of operation or 30 days (whichever comes first)

*Operation in a salt water area is considered "**Severe Service.**"

1. Carefully check steering system components for wear. Replace worn parts.
2. Check steering system fasteners to be sure that they are torqued to correct specifications.

NOTE: Ride-Guide Steering Cables are lubricated at the factory and require no additional lubrication at initial installation.

⚠ WARNING

Core of each steering cable (transom end) must be fully retracted into cable housing before lubricating cable. If cable is lubricated while extended, hydraulic lock of cable could occur.

3. With core of Ride-Guide Steering Cable (transom end) fully retracted, lubricate transom end of steering cables thru grease fittings (a) with 2-4-C w/Teflon (92-825407A12). Lubricate exposed portion of cable ends (b) with 2-4-C w/Teflon.
4. Lubricate pivot points (c) of steering link rods and ball joints (d) of link rods/steering coupler with SAE 30W Motor Oil.
5. Inspection and lubrication of steering head assembly (rotary or straight rack) should be performed once each year (by your Authorized Dealer) or whenever steering mount and/or steering head are disassembled, or if steering effort has increased. Lubricate with 2-4-C w/Teflon.

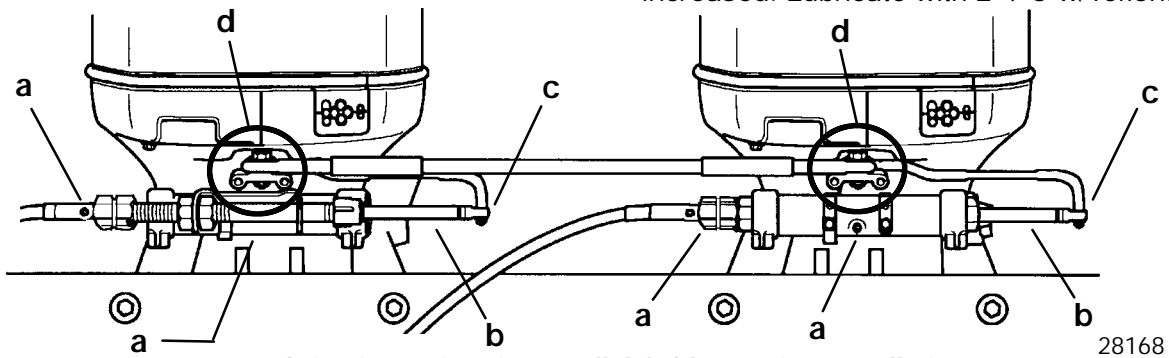

Lubrication Points for Parallel Cable Routing Installations

28168

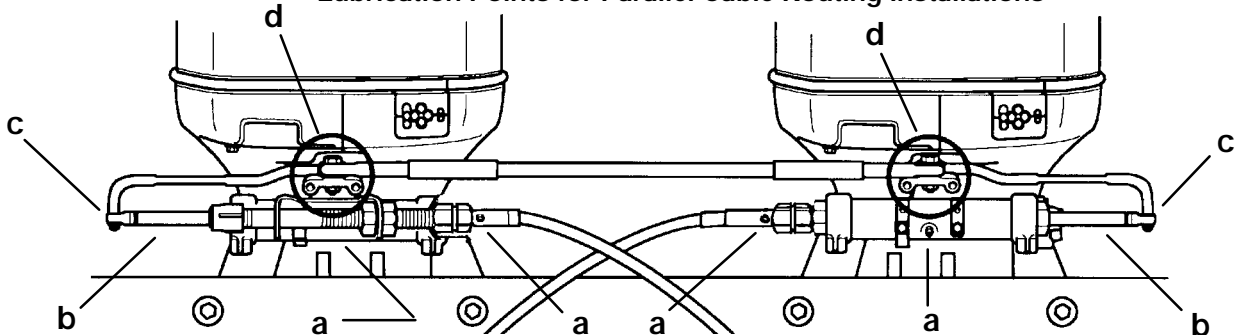

Lubrication Points for Opposite Side Cable Routing Installations

28175



Transom Mounted Ride Guide Attaching Kit Installation (73770A1)

Attaching Kit Installation

1. Lubricate both holes in pivot block (Figure 1) with Quicksilver 2-4-C w/Teflon.
2. Place pivot block on pivot spacer and secure to transom bracket with 3/8 in. x 2-1/2 in. (9.5mm x 63.5mm) bolt, flat washer and locknut, as shown in Figure 1. Torque locknut to 20 lb. ft. (27.1 N·m).

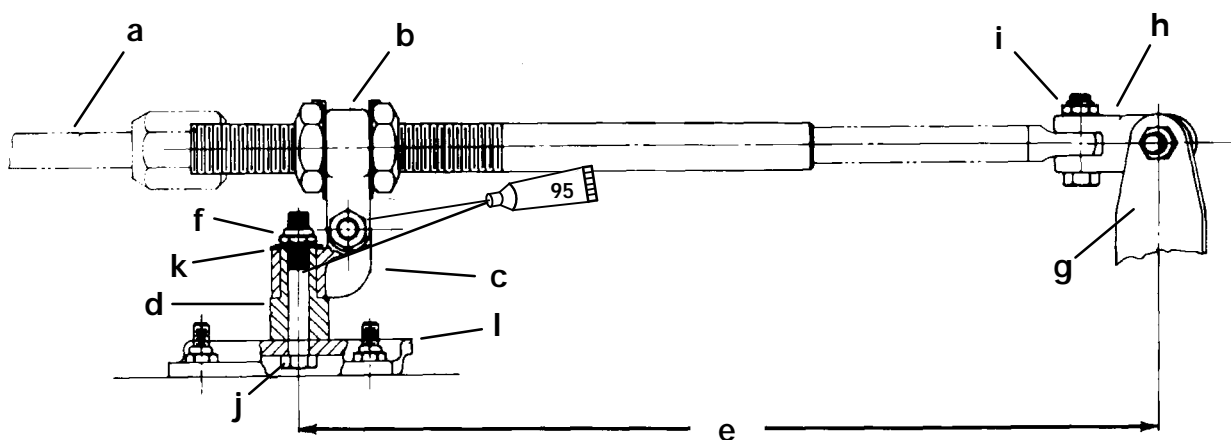

95 2-4-C With Teflon (92-825407A12)

Figure 1

- a - Ride-Guide Cable
- b - Ride-Guide Yoke
- c - Pivot Block
- d - Pivot Spacer
- e - 15 in. (381mm) (Centerline of Attaching Kit Pivot to Centerline of Outboard)
- f - Pivot Attaching Locknut [Torque to 20 lb. ft. (27.1 N·m)]
- g - Outboard Steering Arm
- h - "Clevis Kit"
- i - Ride-Guide Cable Attaching Locknut [Torque to 10 lb. ft. (13.6 N·m)]
- j - Bolt [3/8 in. x 2-1/2 in. (9.5mm x 63.5mm)]
- k - Flat Washer
- l - Transom Bracket

3. Place Ride-Guide yoke on pivot block and secure with 7/16 in. x 1-3/4 in. (11.1mm x 44.5mm) bolt and locknut, as shown in Figures 1 and 2. Torque locknut to 10 lb. ft. (13.6 N·m), **then back off 1/4-turn.**

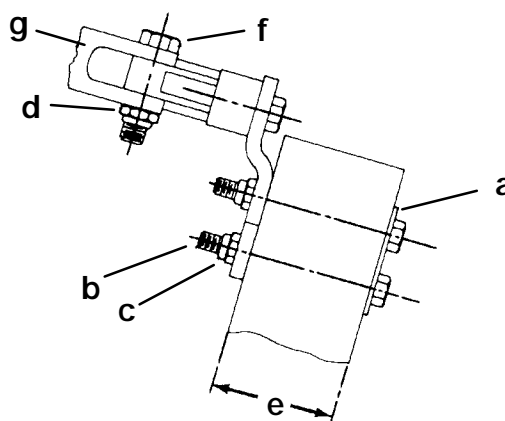

Figure 2

- a - Transom Backing Plate
- b - Bolt [5/16 in. x 3-1/4 in. (7.9mm x 82.5mm)]
- c - Locknut [Torque to 10 lb. ft. (13.6 N·m)]
- d - Ride-Guide Yoke Attaching Locknut [Torque to 10 lb. ft. (13.6 N·m) **Then Back Off 1/4-Turn**
- e - 2-3/8 in. (60.3mm) Maximum Transom Thickness
- f - Bolt [7/16 in. x 1-3/4 in. (11.1mm x 44.5mm)]
- g - Ride-Guide Yoke



4. Install one cable tube jam nut onto steering cable tube. Place tab washer over Ride-Guide yoke, then insert cable tube thru tab washer and yoke. Install second cable tube jam nut onto cable tube but do not tighten at this time. (Figure 3)
5. Position transom attaching kit on transom as
 - a. Determine centerline of outboard, then measure 15 in. (38.1cm) over from this

centerline and draw a vertical line on transom. (Figure 1)

- b. Position attaching kit on transom so that **transom bracket is centered on the 15 in. (38.1mm)** (Figure 1) at a height where the **center of Ride-Guide yoke is even with, or not more than 1/2 in. (12.7mm) above top edge of transom.** (Figure 3)

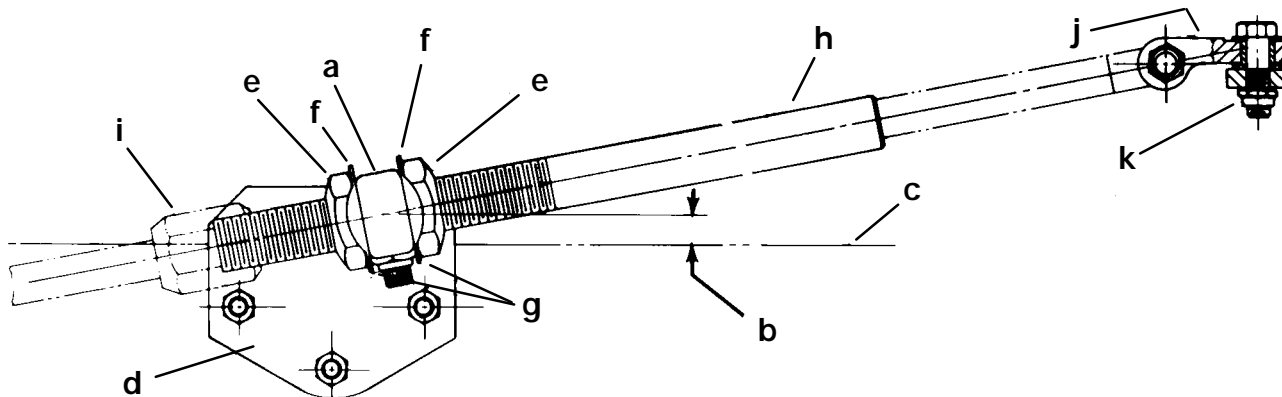

- a - Ride-Guide Yoke
- b - 0 in. to 1/2 in. (0mm to 12.8mm) (Center of Ride-Guide Yoke to Top of Transom)
- c - Top of Transom
- d - Transom Bracket
- e - Cable Tube Jam Nuts [Torque to 35 lb. ft. (47.5 N·m)]
- f - Tab Washer
- g - After Jam Nuts Are Torqued to Specification, Bend Locking Tabs against Nuts
- h - Cable Guide Tube
- i - Ride-Guide Cable Attaching Nut [Torque to 35 lb. ft. (47.5 N·m)]
- j - "Clevis Kit"
- k - Clevis Attaching Locknut [Torque to 20 lb. ft. (27.1 N·m)]

NOTE: When drilling thru transom, be sure that holes are drilled perpendicular to transom.

6. With attaching kit positioned as outlined preceding, use 3 holes in transom bracket as a guide and drill three 11/32 in. (8.7mm) holes thru transom.
7. Use a marine-type sealer on three 5/16 in. x 3-1/4in. (7.9mm x 82.6mm) bolts. Secure attaching kit to transom, using transom backing plate, 3 bolts (with sealer) and 3 locknuts, installed as shown in Figure 2. Torque lock nuts to 10 lb. ft. (13.5 N·m).

STEERING CABLE INSTALLATION

1. Lubricate steering cable end with Quicksilver 2-4-C w/Teflon (92-825407A12).

Figure 3

2. Install steering cable thru steering cable tube and secure to cable tube with cable attaching nut. (Figure 3) Do not tighten cable attaching nut at this time.
3. Attach Ride-Guide cable to outboard steering arm, using the proper "Clevis Kit." Installation instructions for clevis are with "Clevis Kit."
4. Adjust 2 large jam nuts on cable tube of attaching kit, so that **steering wheel** is in normal straight-driving position with outboard in straight-running position. Torque each jam nut to 35 lb. ft. (47.5 N·m), then bend a side of tab washer against flat of each jam nut. (Figure 3)
5. Torque Ride-Guide cable attaching nut (which secures cable to guide tube) to 35 lb. ft. (47.5 N·m). (Figure 3) Install locking sleeve over cable attaching nut and secure with cotter pin. Spread ends of cotter pin.

⚠ WARNING

After installation is completed (and before operating outboard), check that boat will turn right when steering wheel is turned right and that boat will turn left when steering wheel is turned left. Check steering thru full range (left and right) at all tilt angles to assure interference-free movement.



Maintenance Instructions

Lubrication and maintenance inspection is owner's responsibility and must be performed at intervals specified, following:

Normal Service - Every 50 hrs. of operation or 60 days (whichever comes first)

***Severe Service** - Every 25 hrs. of operation or 30 days (whichever comes first)

*Operation in a salt water area is considered "**Severe Service.**"

⚠ CAUTION

Core of steering cable must be fully retracted into cable housing when lubricating cable. If cable is lubricated while extended, hydraulic lock of cable could occur.

1. Lubricate outboard end of Ride-Guide steering cable (thru grease fitting next to cable attaching nut) with Quicksilver 2-4-C w/Teflon.

NOTE: Ride-Guide steering cable is lubricated at the factory and requires no additional lubrication at initial installation.

2. Lubricate all steering system pivot points (and exposed portion of steering cable core) with Quicksilver 2-4-C w/Teflon. Lubricate at intervals specified preceding.
3. Carefully check steering system components for wear (at intervals specified, preceding). Replace worn parts.
4. Check steering system fasteners (at intervals specified, preceding) to be sure that they are torqued to correct specifications. (Figures 1, 2 and 3)

Clevis Attaching Kit Installation (A-70599A2)

NOTE: This kit is used to attach Ride-Guide cable to outboard steering arm **ONLY** when "**Transom Mounted Ride-Guide Attaching Kit**" is being used. If Ride-Guide cable is installed thru outboard tilt tube, then "**Steering Link Rod**" must be used.

Installation Instructions

1. Install clevis to steering cable as shown.
2. Lubricate 3/8 in. x 1-3/8 in. (9.5mm x 34.9mm) bolt (area without threads) with 2-4-C w/Teflon, then secure clevis to steering cable with this bolt and a locknut. Torque locknut (item "d") to 10 lb. ft. (13.6 N·m).

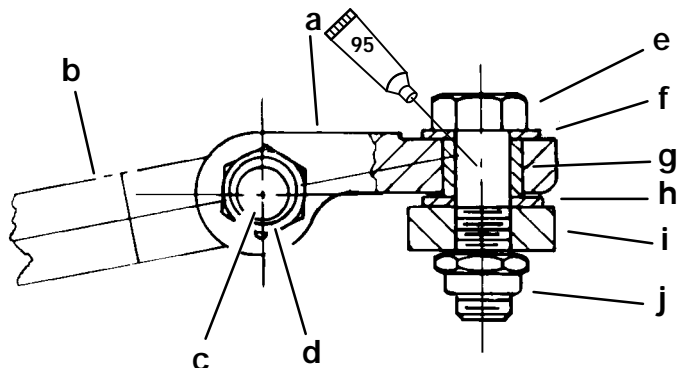

 2-4-C With Teflon (92-825407A12)

- a - Clevis
 - b - Steering Cable
 - c - Bolt [3/8 in. x 1-3/8 in. (9.5mm x 34.9mm)]
 - d - Clevis to Steering Cable Locknut [Torque to 10 lb. ft. (13.6 N·m)]
 - e - Bolt [3/8 in. x 1-1/4 in. (9.5mm x 31.8mm)] [Torque to 20 lb. ft. (27.1 N·m)]
 - f - Thin Washer [1/16 in. (1.6mm) Thick]
 - g - Spacer
 - h - Thick Washer [1/8 in. (3.2mm) Thick]
 - i - Engine Steering Arm
 - j - Clevis to Engine Locknut [Torque to 20 lb. ft. (27.1 N·m)]
3. Lubricate spacer (supplied with this kit) with 2-4-C w/Teflon.
 4. Attach clevis to top of outboard steering arm with a 3/8 in. x 1-1/4 in. (9.5mm x 31.8mm) bolt, thin washer, spacer, thick washer (thick washer must be installed between clevis and steering arm) and locknut, as shown. Torque bolt (item "e") to 20 lb. ft. (27.1 N·m), then torque locknut (item "j") to 20 lb. ft. (27.1 N·m).



Maintenance Instructions

Lubrication and maintenance inspection is owner's responsibility and must be performed at intervals specified, following:

Normal Service - Every 50 hrs. of operation or 60 days (whichever comes first)

***Severe Service** - Every 25 hrs. of operation or 30 days (whichever comes first)

*Operation in a salt water area is considered "**Severe Service.**"

1. Carefully check steering system components (at intervals specified, preceding) for wear. Replace worn parts.
2. Check steering system fasteners (at intervals specified, preceding) to be sure that they are torqued to correct specifications.
3. Lubricate clevis pivot points with a drop of light oil. Lubricate at intervals specified, preceding.